

Catalog

1 INTRODUCTION	- 1 -
1.1 BRIEF DESCRIPTION	- 1 -
1.2 OPERATING PRINCIPLE	- 1 -
1.3 APPLICATION	- 1 -
2 CONFIGURATION AND CHARACTERISTIC	- 1 -
2.1 CONFIGURATION	- 1 -
2.2 CHARACTERISTIC	- 2 -
3 INSTALLATION	- 2 -
3.1 BEFORE INSTALLATION	- 2 -
3.2 GRAPHIC ILLUSTRATION	- 2 -
3.3 INSTALLATION POSITION	- 3 -
3.4 PRESSURE/VACUUM	- 5 -
3.5 MOISTURE	- 5 -
4 CONNECTING TO POWER SUPPLY	- 6 -
4.1 SAFETY INSTRUCTIONS	- 6 -
4.2 CABLE CONNECTION	- 6 -
4.3 WIRING DIAGRAM	- 6 -
5 MEASURING MODE	- 6 -
5.1 DISTANCE MEASUREMENT	- 6 -
5.2 LEVEL MEASUREMENT	- 7 -
5.3 LOW POINT RANGE	- 8 -
5.4 HIGH POINT RANGE	- 8 -
5.5 OPERATION WITH RELAY	- 8 -
6 MENU AND OPERATING INSTRUCTIONS	- 8 -
6.1 LANGUAGES	- 9 -
6.2 MENU INSTRUCTIONS OF USER SET	- 9 -
6.3 MENU INSTRUCTIONS OF FACTORY SET	- 9 -
6.4 PARAMETER LOCK	- 10 -
6.5 RANGE SETTING	- 11 -
6.6 MEASURE TYPE	- 12 -
6.7 TRANSDUCER SET (PLEASE DO NOT MODIFY THIS PARAMETER)	- 13 -
6.8 ALGORITHM SELECT (PLEASE DO NOT MODIFY THIS PARAMETER)	- 13 -
6.9 ALARM SETTING	- 14 -
6.10 CALIBRATION (PLEASE DO NOT MODIFY THIS PARAMETER)	- 14 -
7 COMMUNICATION	- 15 -
7.1 COMMUNICATION SETTING	- 15 -
7.2 RESET	- 16 -
8 FAULT ANALYSIS AND MAINTENANCE	- 17 -
9 TECHNICAL DATA	- 18 -
10 DIMENSIONS	- 19 -
11 INSTRUMENT REPAIR	- 19 -
12 STORAGE AND TRANSPORT	- 19 -
12.1 PACKAGING	- 19 -
12.2 TRANSPORT	- 19 -
12.3 STORAGE	- 20 -

1 Introduction

1.1 Brief description

Ultrasonic Level Transmitter is specifically designed for continuous non-contact liquid level measurement. The transducer (probe) sends out high frequency ultrasonic pulses. When a pulse hits the surface of liquid, it is partially reflected. The reflected wave is received by the transducer and converted into an electronic signal. The distance from the transducer to the liquid surface is calculated according to the time difference between pulse transmission and reception and velocity of sound wave. Because the Ultrasonic Level Transmitter sensor is contactless, it can provide reliable continuous level measurements for applications in various open pools, for example, water pools in sewage treatment and other water resources in hydraulic and hydrological surveys.

1.2 Operating principle

The transducer sends out high frequency ultrasonic pulses. When a pulse hits liquid surface, it is reflected back. The reflected ultrasonic wave is received by the transducer and converted into an electronic signal. The time interval between transmitted ultrasonic pulse and received ultrasonic pulse is directly proportional to the distance between transducer and liquid surface. The relationship between sound wave travel distance S , travel speed C and time interval T can be expressed by a formula: $S=C \times T/2$.

1.3 Application

- (1) In various open pools, such as sewage water tanks/pools, or for hydraulic and hydrological surveys in reservoirs, rivers and lakes, etc.
- (2) Applications under corrosive environments, such as biochemical reaction pools and sedimentation tanks, etc.

2 Configuration and characteristic

2.1 Configuration

As shown in Fig. shown, Uson-11 consists of the components:

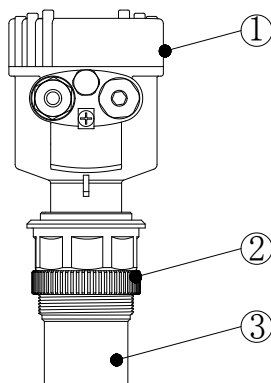

Fig. 1 Uson-11 Configuration

- ① Aluminum-alloy housing cover ② Lock nut ③ Transducer

2.2 Characteristic

- (1) With three selectable ranges (5m, 10m and 15m).
- (2) With temperature compensation function, offers high accuracy and strong adaptability.
- (3) RS-485 communication interface to reach real time monitoring, convenient and efficient.
- (4) Special echo signal processing algorithm is used, can effectively avoid false echo waves.
- (5) With IP66/IP67 Ingress Protection rating.
- (6) Preventing strong corrosion with PVDF transducer.
- (7) Convenient operation on language setting.
- (8) With CE certificates. Contactless measurement ensures no wear during operation and virtually maintenance-free.
- (9) EMC design of the product complies with IEC61000-4 (GB/T 17626.2) standard in EFT (LT: A), ESD (LT: A) and surge.

3 Installation

3.1 Before installation

Before installation, please affirm that the instrument model is suitable for the occasion and environment. In order to ensure the instrument work normally after installation, please be aware of process pressure, process temperature as well as the chemical properties of the medium.

3.2 Graphic illustration

Measurement range (working range) and the maximum measuring distance are shown in Figure 2.

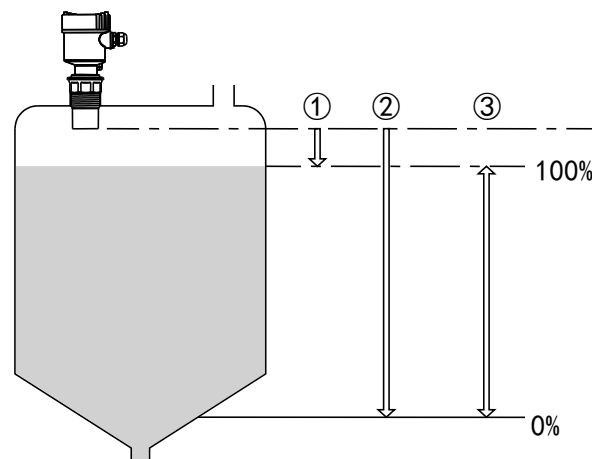
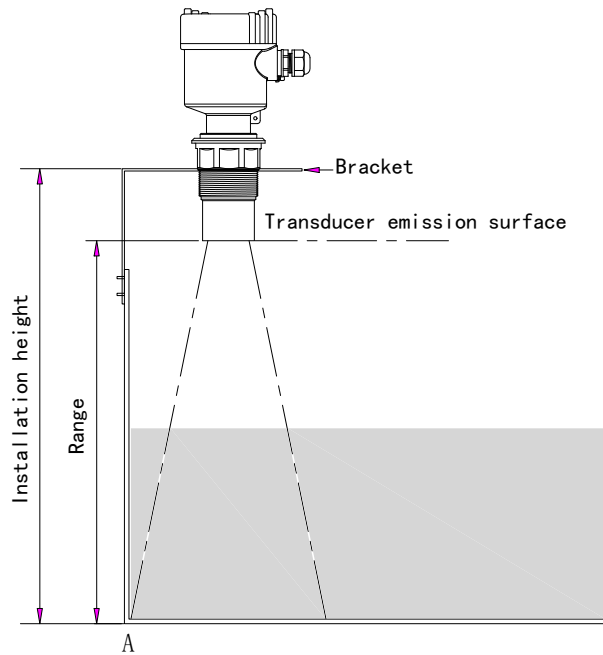

Fig. 2 Measuring range (working range) and maximum measuring distance

① Full ② Empty (maximum measuring distance) ③ Measurement range

3.3 Installation position

Trench installation diagram



1. Please mind the load capacity of bracket during instrument installation.
2. Projection of beam angle on the bottom of trench must be within the boundary of trench wall (point A).
3. Make sure installation height is properly matched with measurement range.

Fig. 3

Flattop tank installation diagram

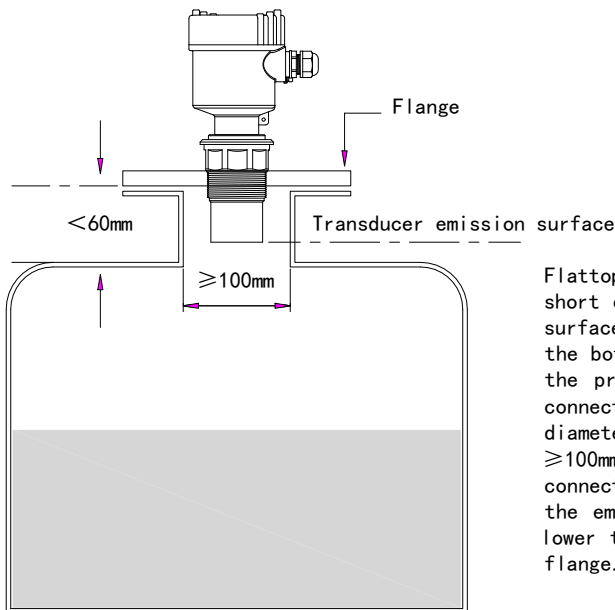

Flattop tank generally has a very short connecting pipe, the reference surface of the connecting pipe is the bottom surface of the flange. On the premise that the length of the connecting pipe is $\leq 60\text{mm}$, the inner diameter of the connecting pipe is $\geq 100\text{mm}$, and the inner wall of the connecting pipe is flat and smooth, the emission surface should be 30mm lower than the bottom surface of the flange.

Fig. 4

Conical tank installation diagram

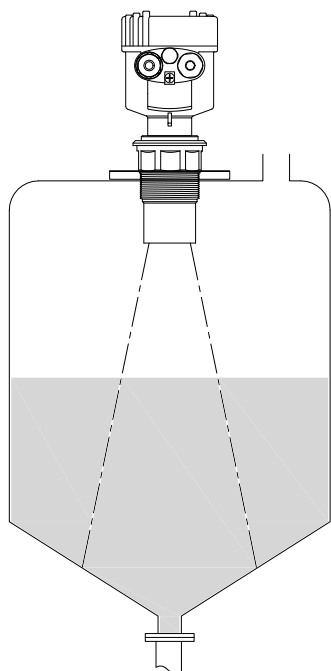

The best installation position for a vessel with flat top and conical bottom is at top center so that measurement can reach to the bottom of vessel.

Fig. 5

Arch tank installation diagram-1

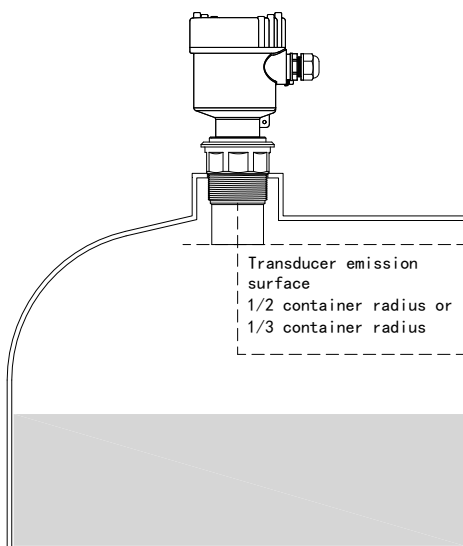

For arch tanks, avoid installing the instrument in the center of the tank top, but to install at 1/2 or 2/3 of the radius of the tank top while keeping a certain distance from the tank wall. For ultrasonic pulses, the arch top is like a convex lens. If the transducer installs at the focus of the convex lens, all false echoes will be received. Therefore, please avoid installing the instrument in the center of the tank top.

Fig. 6

Arch tank installation diagram-2

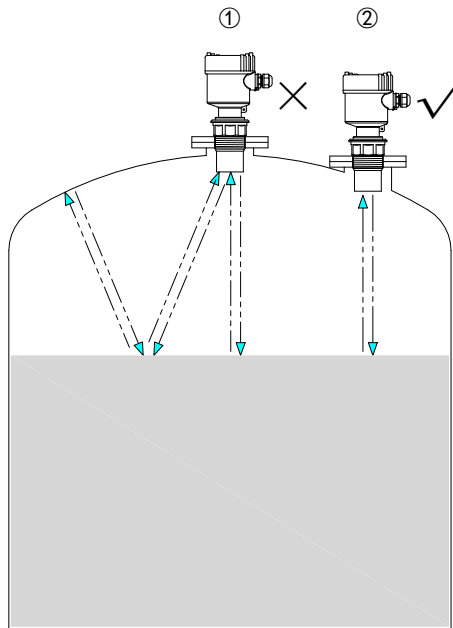

1. False installation: please do not install instrument at the top center of arch tank to avoid false echo signal due to multiple reflections.
2. Correct installation: install instrument at 1/2 or 2/3 of the radius on the top of arch tank.

Fig. 7

3.4 Pressure/Vacuum

Uson-11 Ultrasonic Level Transmitter is suitable for atmospheric environment. Overpressure or negative pressure will affect sound wave velocity, as well as the measurement accuracy. Severe overpressure or negative pressure will cause instrument work abnormally.

3.5 Moisture

When the instrument is mounted in outdoors or high humidity areas, please lead the connection cable downwards in front of cable entry, thus the rain and condensation water can drain off and give your instrument additional protection against moisture penetration. See Figure 8 as reference.

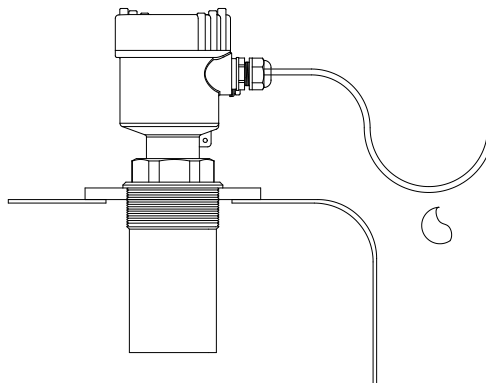

Fig. 8: Moisture mounting

4 Connecting to power supply

4.1 Safety Instructions

- (1) In consideration of safety, wiring is only allowed in the complete absence of voltage.
- (2) You must follow the corresponding installation regulations for Ex applications.

4.2 Cable connection

In general, Uson-11 uses general cable with round cross-section. To ensure its sealing effect, outer diameter is 5-9mm.

If you are using cable with a different diameter or cross-section, please use matched cable bolt, and be aware of changed cable's sealing ability.

4.3 Wiring diagram

Please wiring safely according to following diagrams (Figure 9).

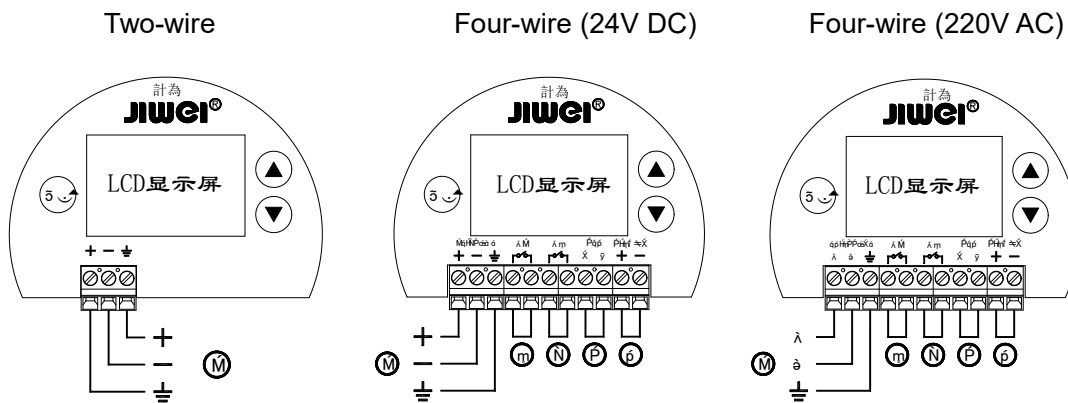

Fig. 9: Wiring diagram

① Power supply ②③ Relay output SPST ④ RS-485 output ⑤ 4~20mA output

5 Measuring mode

Measuring mode includes distance measurement and liquid level measurement. Default setting is liquid level measurement.

5.1 Distance measurement

The setting reference of zero point is meaningless. The positions of high point range and low point range are shown in Fig. 10.

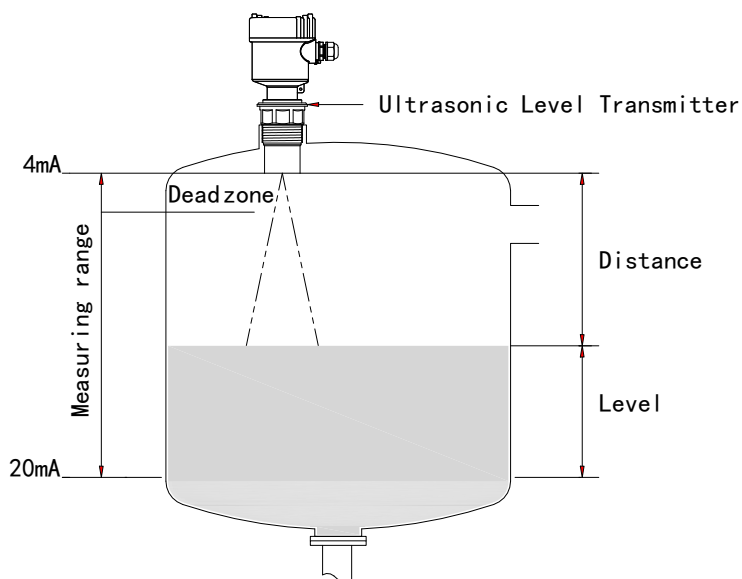

Fig.10: Distance measurement

5.2 Level measurement

The positions of the reference of zero point, high point range and low point range are shown in Fig. 11.

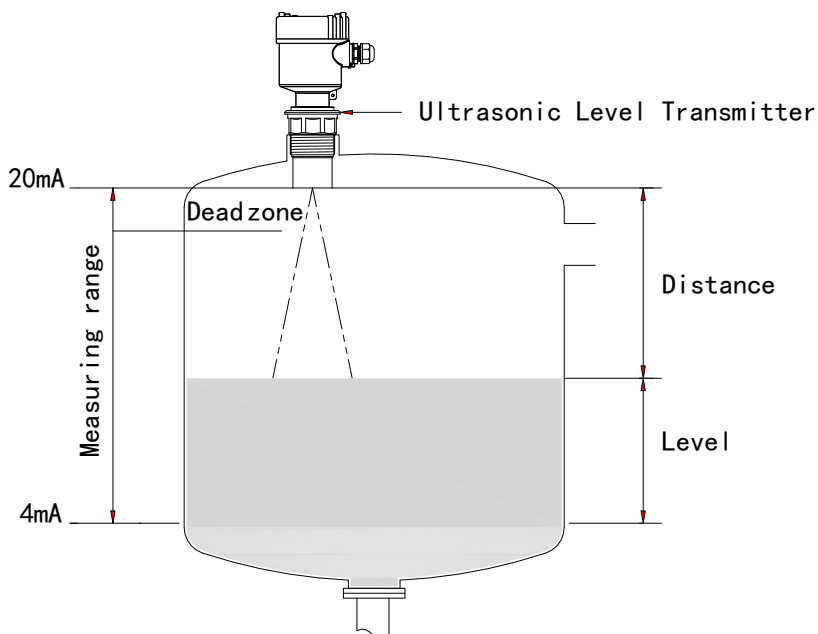

Fig.11: Level measurement

5.3 Low point range

The distance between reference level to low point range, the value is positive when low point range is higher than reference level; the value is negative when it is lower than reference level, if liquid level is at this position, the output current will be 4mA.

5.4 High point range

The distance between reference level to high point range, the value is positive when high point range is higher than reference level; the value is negative when it is lower than reference level, if liquid level is at this position, the output current will be 20mA

5.5 Operation with relay

(1) Enter alarm setting and set three parameters;

(2) Alarm mode: select high level alarm, low level alarm or off;

(3) Alarm value

High level alarm: alarm when liquid level is higher than the alarm value;

Low level alarm: alarm when liquid level is lower than the alarm value;

(4) The returned difference value is to prevent measuring error from causing the alarm switch to jump repeatedly near alarm point,

High alarm state: when liquid level is lower than (alarm value - returned difference value), the alarm will be cleared.

Low alarm state: when liquid level is higher than (alarm value + returned difference value), the alarm will be cleared;

(5) Please guided by the technical engineer to setparametercalibration and algorithm selection, as well as probe selection;

(6) After set up, instrument must be grounded separately. DO NOT ground with the electrical box or instrument box;

(7) Recommend: when Ultrasonic Level Transmitter is connected with the inverter, PLC and other interference equipment, the power supply portion should be equipped with isolation transformer, and the signal portion should be equipped with signal isolator, as well as tobe grounded reliably.

★Signal cablecannot be in the same slot as the power cable and power cable. It shall be installed separately through metal pipe or far away from power cables. On the premise of no pipe installation, the distance from power cables shall be at least 1 m.

6 Menu and operating instructions

The instrument can be debugged through the three buttons on the display panel. After debugging, the measured value is displayed on the LCD screen.



◆ Enter menu

◆ Confirm menu items

◆ Confirm parameter



◆ Move the cursor

◆ Select menu items

◆ Modification





After the powered-on and displayed, press and hold the **"Set"** button for two seconds to enter the primary menu.

Menu modes include **Factory set** mode and **User set** mode.

6.1 Languages

There are two languages: Simplified Chinese and English.

Please press both   button and hold for 5 seconds to switch the languages.

6.2 Menu instructions of user set

Note: when first entering the menu, please press and hold the **"Set"** button for 2 seconds.

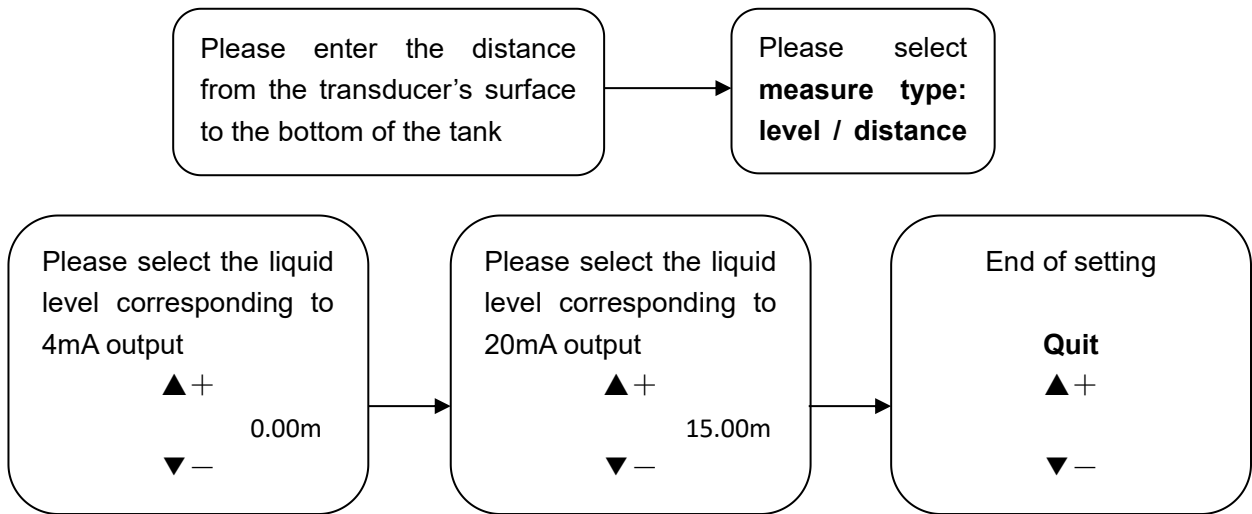
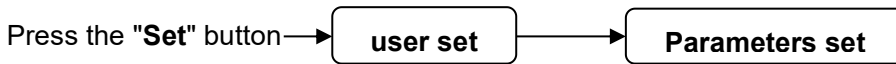

6.3 Menu instructions of factory set

(1) Press **"Set"** button into mode selection.

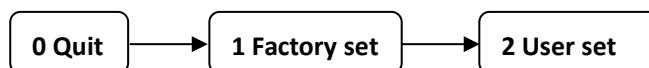

(2) Instructions for entering the **"1 Factory set"** menu:

- The primary menu when parameters are not locked;

- Press "▲" or "▼" to the modified menu, and then press "Set" to enter this menu.
- To quit this menu, press "Set"

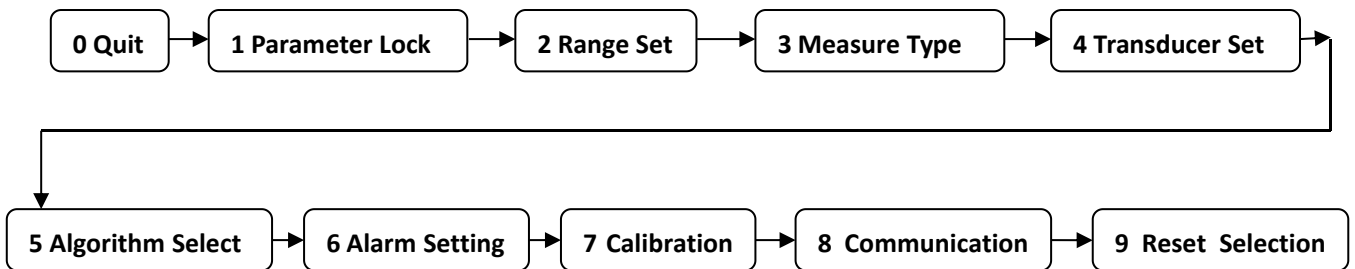

(3) When select "0 Quit" while pressing "Set" button, will back to mode selection menu.



6.4 Parameter lock

Primary menu of "Parameter lock":

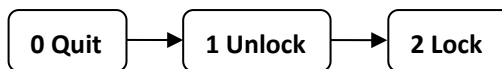

When parameters are set and don't want others to modify, please lock the menu. Therefore, user needs to enter a password to unlock the menu. The initial password is **25**, users can modify the initial password and set their own password (special reminder: please remember the password. If you forget, please contact us).

Note

Unlock: anyone can modify the parameters.

Lock: password need to be entered to modify the parameters.

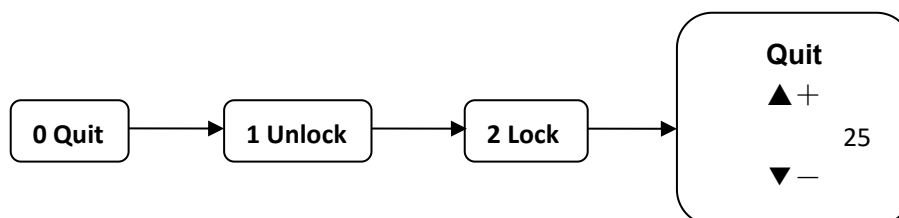

When the parameter is locked, press "Set" button to enter the "Unlock" menu:

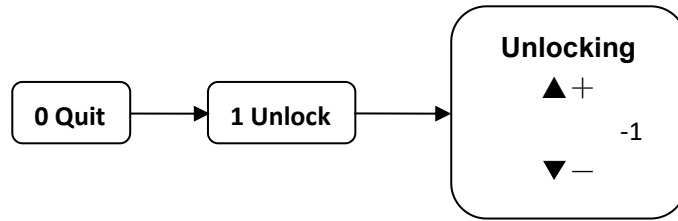

6.5 Range setting

Set **Bottom Distance** (reference zero point), **Range-L** (range low point), **Range-H** (range high point) and **Unit Selection**.

Bottom Distance: reference zero point, for Level measurement. Factory default setting is the **Maximum Range**.

Range-L: set the measure value corresponding to the output of 4mA. Factory default setting is **0**.

Range-H: set the measure value corresponding to the output of 20mA. Factory default setting is the **Maximum Range**.

Unit Selection: there are three units: m, cm and mm. m: displayed in meters, cm: displayed in centimeters, mm: displayed in millimeters. Factory default setting is **m**.

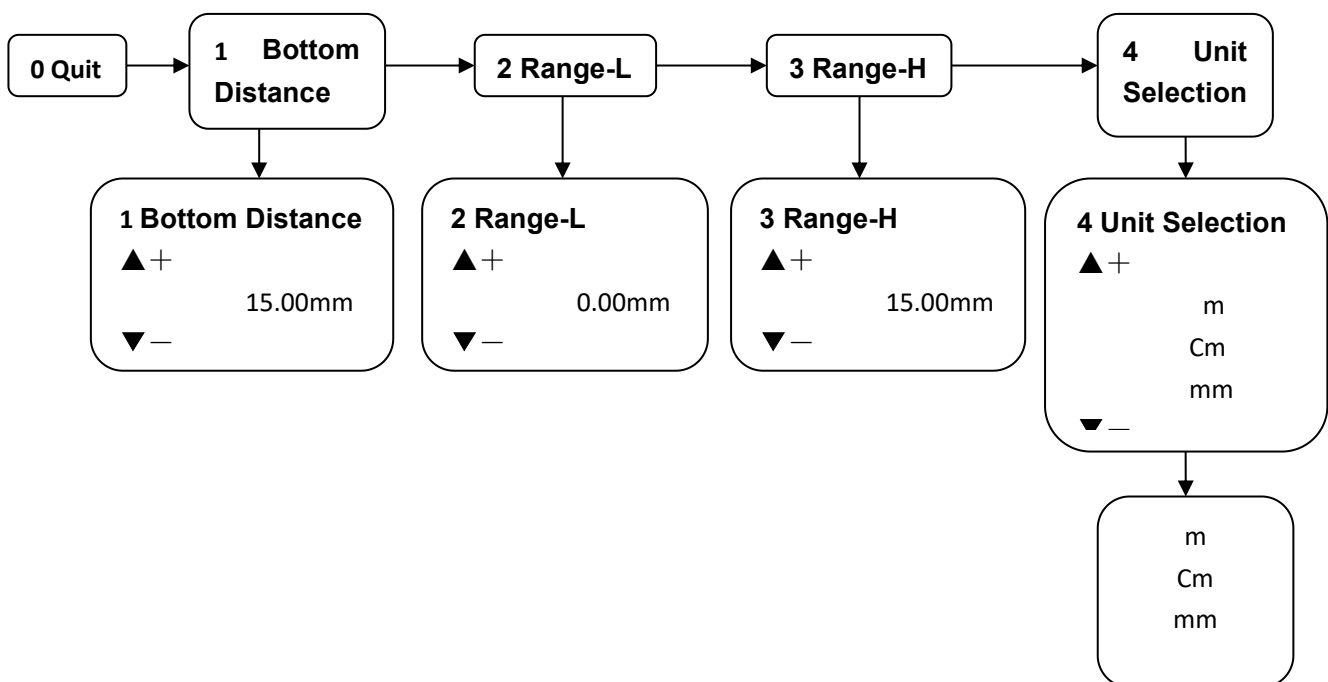

6.6 Measure type

Type Selection: you can select **Level** or **Distance**. Factory default setting for **Type Selection** is **Level**.

Distance: the displayed value is the distance from the transducer to the measured surface.

Level: the displayed value is the height from the tank bottom to the measured surface, that is, the liquid level height.

Damping Rate: there are three options, **Slow**, **Middle** and **Fast**.

Slow: slow response rate, but high in measurement accuracy, and it is not easy to be interfered;

Middle: between slow and fast;

Fast: fast response rate, but low in measurement accuracy, and easy to be interfered.

Factory default setting for **Damping Rate** is **Middle**.

Safe Level: four options of **Hold**, **Minimum**, **Maximum** and **Setting Value**.

Hold: the displayed value after wave loss of the system is the last measured value, and the current is the corresponding value;

Minimum: the displayed value after wave loss of the system is 4mA, and the current is 4mA;

Maximum: the displayed value after wave loss of the system is 20mA and the current is 20mA;

Setting Value: the displayed value after wave loss of the system is the last measured value, and the current output is the set value of the set current. Factory default setting **Safe Level** is **Hold**.

Set Current: set the output current after wave loss, which is greater than 3.6mA and less than 22mA. It is invalid when it is selected as hold / maximum / minimum value. Factory default setting is 3.6mA.

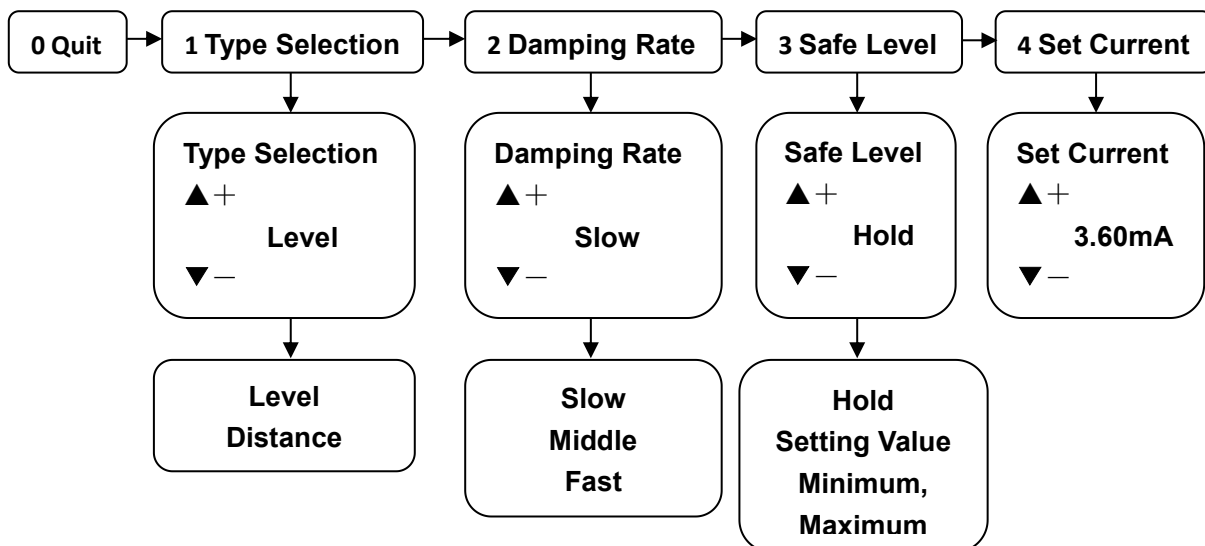

6.7 Transducer set (please DO NOT modify this parameter)

Select the transducer and relevant parameters.

- (1) **Probe selection:** can be selected from 1 to 9. According to the label on the transducer, factory default setting is 5.
- (2) **Blanking:** set the near end blind area of the transducer. Factory default setting varies according to different transducer
- (3) **Sensitivity S:** please do not modify. It can only be modified under the guidance of professional technicians.
- (4) **Threshold S:** please do not modify. It can only be modified under the guidance of professional technicians.
- (5) **Sensitivity L:** please do not modify. It can only be modified under the guidance of professional technicians.
- (6) **Threshold L:** please do not modify. It can only be modified under the guidance of professional technicians.

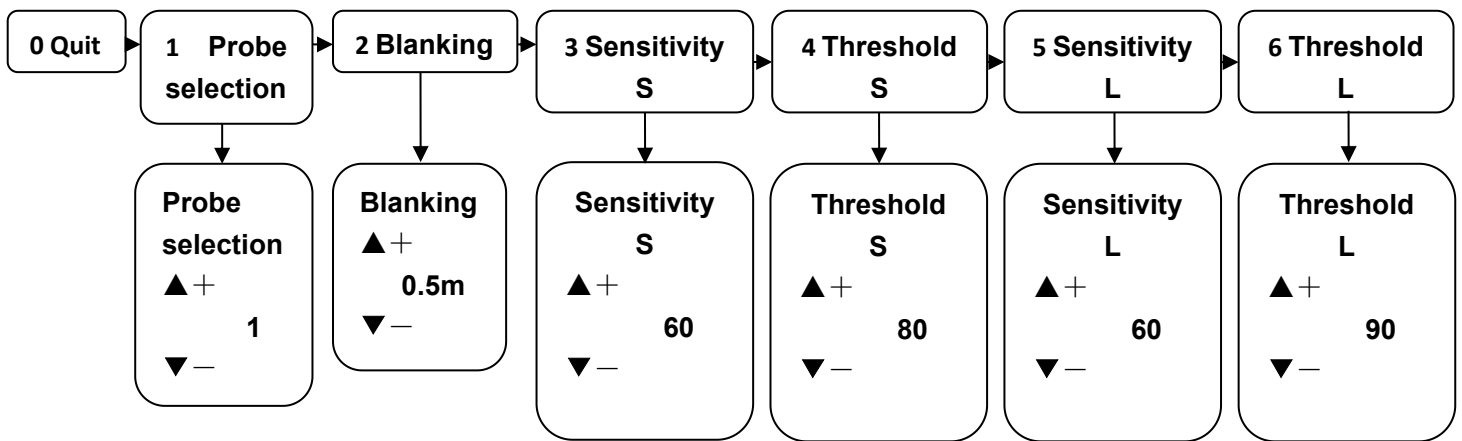

6.8 Algorithm Select (please DO NOT modify this parameter)

Algorithm Select: special environment 1 to 7 can be selected. Factory default setting is environment 7.

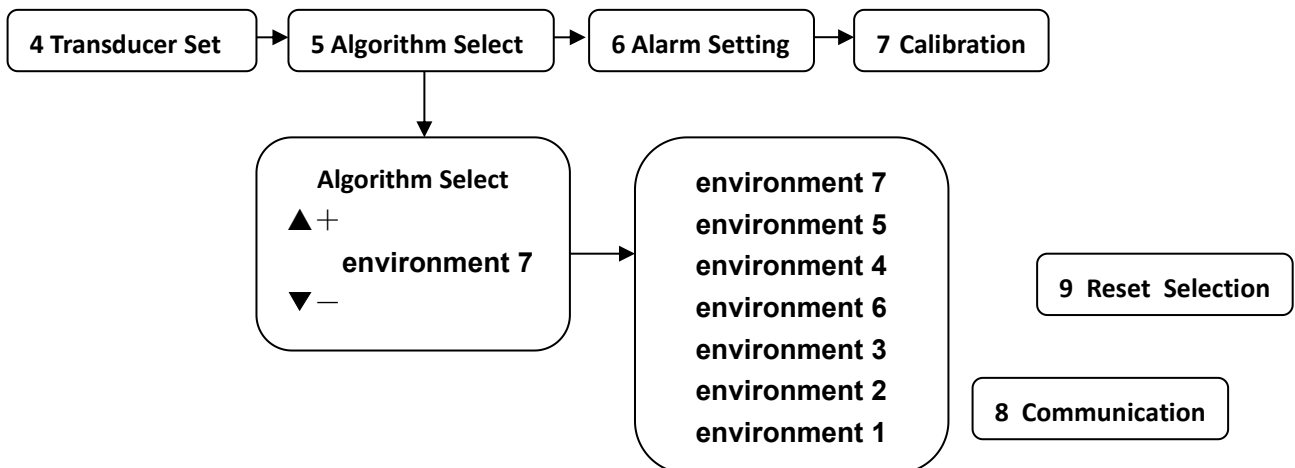

6.9 Alarm setting

Set alarm relay.

Alarm1 Mode: there are three options: **Close**, **Low Alarm** and **High Alarm**. **Close:** relay 1 does not work; **Low Alarm:** relay 1 low level alarm; **High Alarm:** relay 1 high level alarm. Factory default setting is **Close**.

Alarm1 Value: in meters, factory default setting is **0**.

Alarm1 Diff (return difference): in meters. After the alarm is triggered, if want to disarm, the measured value has to reaches the alarm value + / -, then alarm return difference is effective. Factory default setting is **0**.

Alarm2 Mode: Alarm3 Mode, Alarm4 Mode are with the same setting method as above.

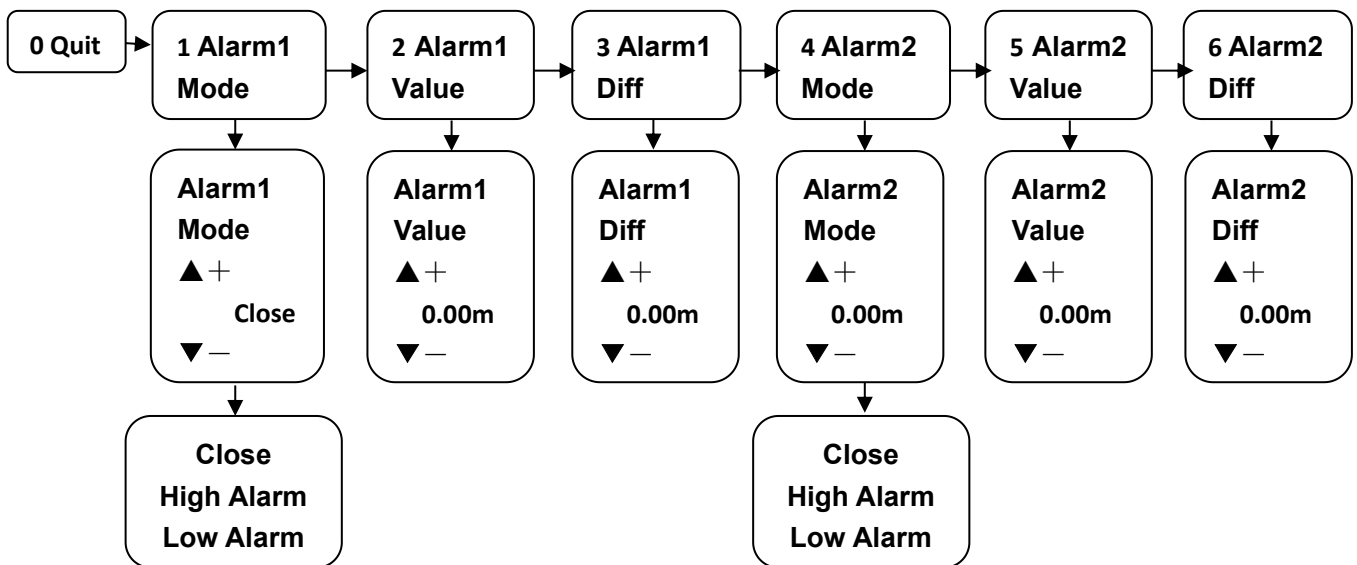

6.10 Calibration (please DO NOT modify this parameter)

Range Adjust: the system will automatically adjust the range.

Sound Adjust: enter the actual value and the system will automatically adjust the sound velocity, which is used in occasions of many volatile gases such as gasoline, acetone and alcohol, the propagation speed of sound in these gases is different from air, and needs to be adjusted corrected.

4mA Adjust: modify the value until the actual output current is 4mA.

When multimeter connects the positive pole of 4-20mA in series connection, have to increase or decrease the number by 1, to enter 4mA Adjust.

20mA Adjust: modify the value until the actual output current is 20mA.

Voltage: enter the voltage value measured at the corresponding test point. The factory default setting is **5.00**.

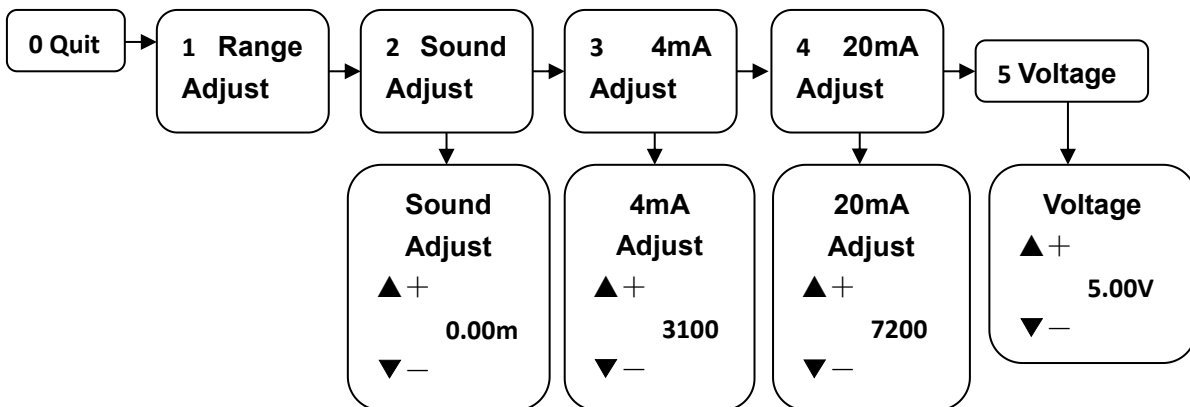

7 Communication

7.1 Communication setting

Address: select the address. Default value is **1**.

Baud Rate: select the communicated frequency, **2400**, **4800**, **9600** and **19200** are selectable. Default value is **9600**.

Working Mode: select the working Mode of communication, including "**Automatic Report**" and "**Inquire Mode**". The default setting is "**Automatic Report**".

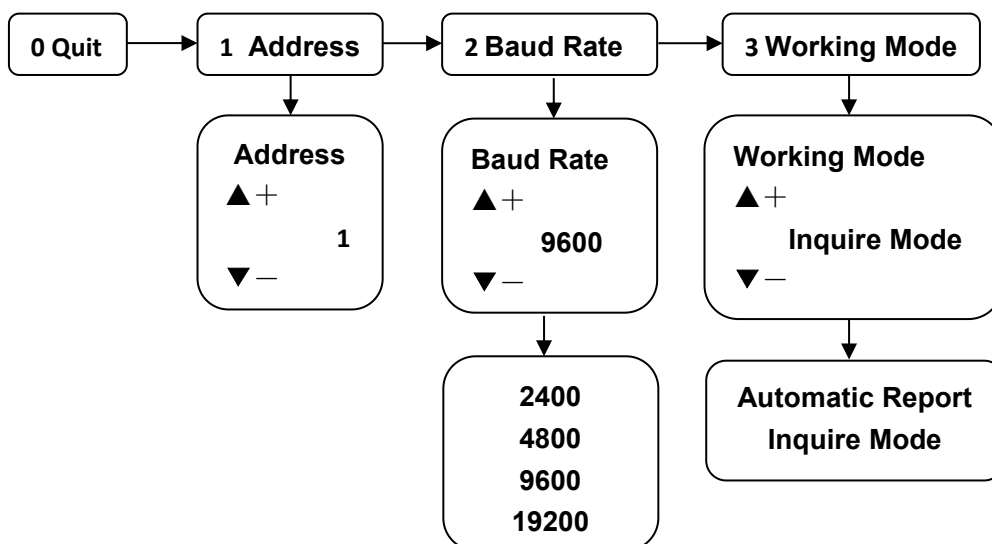

7.2 Reset

Factory Reset: Yes, back to factory set. The problem of setting error can be solved. No, to exit. Default setting is **No**.

System Reset: Yes, back to system set. No, to exit. Default setting is **No**. (Please do not modify this parameter).

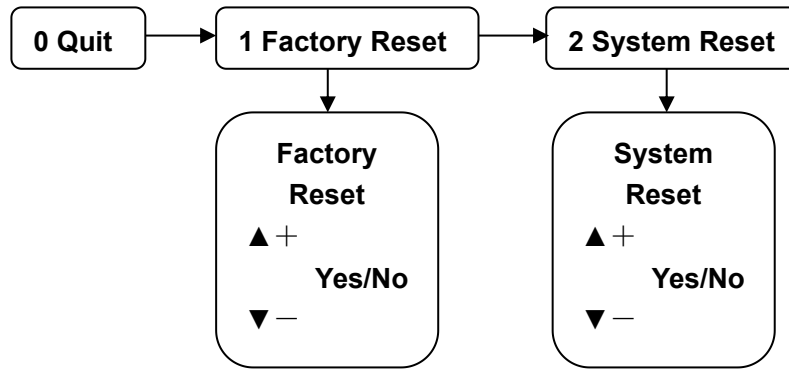

8 Fault analysis and maintenance

When faults occur, after checking all wiring is normal and instrument is correctly grounded, press "▲" button, and then press and hold "set" button until there is an echo menu. Please take a picture of the echo menu and send it to us with, then we can distinguish whether it is electromagnetic interference, false echo, blind zone or no echo signal received and so on.

Problems	Reasons	Solutions
Instrument out of service	Power supply is not connected properly	Check power supply
Instrument does not display	<ol style="list-style-type: none"> 1. Power supply is not connected properly 2. The wiring between LCD screen and mainboard falls off or loosens 3. LCD damaged 	<ol style="list-style-type: none"> 1. Check power supply 2. Check power supply and reconnect 3. Depot repair
<p>When instrument works, the small horn symbol remains on the screen, if shown as “”, indicates that the system enters wave loss state</p>	<ol style="list-style-type: none"> 1. Distance is beyond measured range. 2. Measured medium has strong disturbance, vibration or heavy dust. 3. There are inverter, motor and other strong interference sources around. 4. The probe is not aligned with measured surface. 5. There are redundant objects in the measured space, such as support rod, filling stream, etc. 6. Instrument enters the blind zone. 7. Measured medium is soft powder. 8. The surface of the measured liquid has foam, and the area of the foam exceeds 30% in the range of ultrasonic emission. 	<ol style="list-style-type: none"> 1. Consider replacing the level meter with a larger measuring range 2. After the measured medium is tranquil, the instrument will automatically resume normal measurement 3. Check surrounding environment and electromagnetic shielding . It is not allowed to use the same power supply with frequency converter and motor, and it should be grounded reliably. 4. Reinstall the probe and make it perpendicular to the liquid level 5. Reselect an appropriate installation location to avoid interference 6. Lift the probe installation position 7. If it is powder, consult the manufacturer 8. Exclude foam medium, if it is powder, consult the manufacturer

9 Technical data

Measurement range	5m, 10m, 15m
Transducer	Standard: ABS
	Anti-corrosion: PVDF
Dead zone	≤0.3m(5m/10m)
	≤0.6m(15m)
Resolution	±0.5% of the measurement range
Beam angle	6° (5mRange) 8° (10mRange) 10° (15mRange)
Accuracy	≤1%
Display	Chinese + English LCD Display
Buttons	Three
Rated input voltage	Four-wire: 85~264V AC 50/60Hz 18~36V DC
	Two-wire: 18~30V DC
Signal output	Two-wire: 4~20mA
	Four-wire: 4~20mA
	Optional: RS-485/Relay
Relay Contact rating	4A 250V AC/30V DC
Ambient temperature	-20~60℃
Process temperature	-20~80℃
Process pressure	Normal
Cable entry	M20×1.5
Housing	Aluminum alloy
Process connection	Thread connection
	Flange connection
Ingress Protection	IP66/IP67
CE	LVD and EMC Certificates

Ex certificate

This instrument fulfills the legal requirements of the applicable Ex guidelines. You can find the Ex conformity declaration in the certification area of “www.jiweimeter.cn”.

10 Dimensions

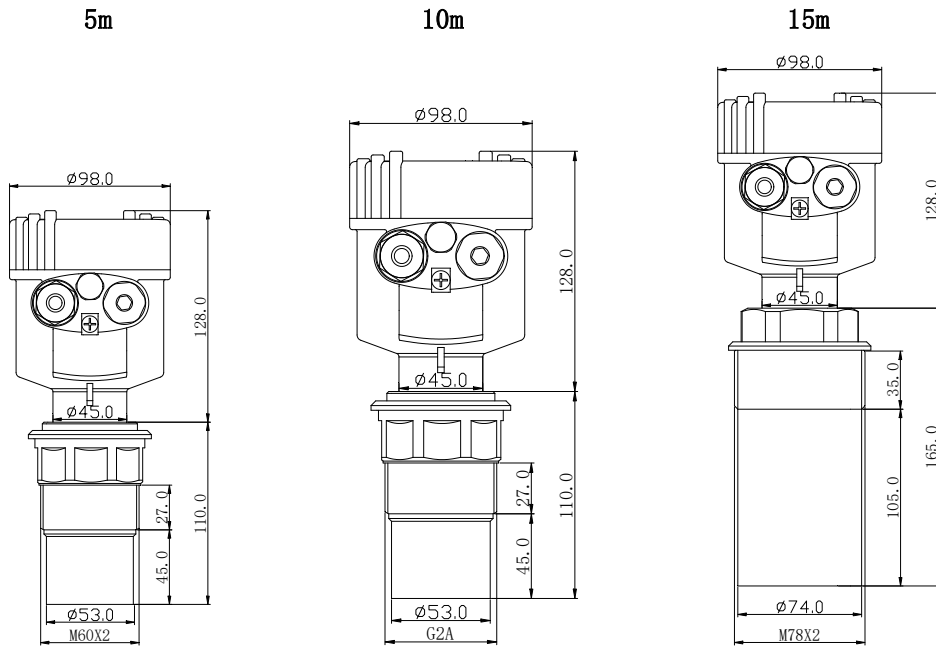

11 Instrument repair

We offer our customers service including technical consulting, user training, on-site installation and commissioning, product replacement and maintenance as well as on-site technical support, etc. Jiwei product quality warranty period is one year, the warranty period for your free maintenance, long-term technical support, if you need advice in use, please call the service hotline: +86-0755-28407683, you can find the relevant services on our website "www.jiweimeter.cn".

12 Storage and transport

12.1 Packaging

Your instrument was protected by packaging during transport.

The packaging of standard instruments consists of environment friendly, recyclable carton cover material. The probe is additionally protected with a cardboard cover. For special version, PE foam or PE foil is also used. Please dispose of the packaging material through specialized recycling companies.

12.2 Transport

Transport must be carried out under consideration of the notes on the transport packaging. Nonobservance of these instructions can cause damage to the instrument.

The delivery must be checked for completeness and possible transit damage immediately at receipt. As certain transit damage or concealed defects must be appropriately dealt with.

12.3 Storage

The packages must be stored under the following conditions:

- (1) Not in the open
- (2) Dry and dust free
- (3) Not exposed to corrosive media
- (4) Protected against solar radiation
- (5) Avoiding mechanical shock and vibration
- (6) Storage environment

Relative humidity: 0~95%

Storage temperature: -20~60°C