

# Contents

<b>1 Introduction .....</b>	<b>- 1 -</b>
1.1 Brief description .....	- 1 -
1.2 Operating principle .....	- 1 -
1.3 Application .....	- 1 -
<b>2 Configuration and characteristic .....</b>	<b>- 2 -</b>
2.1 Configuration .....	- 2 -
2.2 Characteristics .....	- 2 -
<b>3 Installation .....</b>	<b>- 2 -</b>
3.1 Before installation .....	- 2 -
3.2 Installation .....	- 3 -
3.3 Mounting direction .....	- 3 -
3.4 Filling openings .....	- 4 -
3.5 Pressure/Vacuum .....	- 4 -
3.6 Moisture .....	- 4 -
<b>4 Electrical connection .....</b>	<b>- 5 -</b>
4.1 Safety noted .....	- 5 -
4.2 Connection cable .....	- 5 -
4.3 Wiring diagram .....	- 5 -
4.4 Wiring procedure .....	- 7 -
4.5 Intrinsic-safe model Ring-11 connection with safety barrier .....	- 7 -
<b>5 Setup .....</b>	<b>- 8 -</b>
5.1 Internal structure .....	- 8 -
5.2 Sensitivity adjustment .....	- 9 -
5.3 Modes switch .....	- 9 -
5.4 Signal lamp .....	- 9 -
5.5 Simulation button (Simul.) .....	- 10 -
5.6 Signal function table .....	- 10 -
<b>6 Fault analysis and maintenance .....</b>	<b>- 13 -</b>
6.1 Fault analysis .....	- 13 -
6.2 Exchanging the electronics .....	- 13 -
6.3 Instrument repair .....	- 14 -
<b>7 Technical data .....</b>	<b>- 14 -</b>
<b>8 Dimensions .....</b>	<b>- 16 -</b>
<b>9 Storage and transport .....</b>	<b>- 19 -</b>
9.1 Packaging .....	- 19 -
9.2 Transport .....	- 19 -
9.3 Storage .....	- 19 -

## 1 Introduction

### 1.1 Brief description

Ring-11 Liquid Level Switch is a highly reliable instrument for liquid level detection and control. The fork length is only 40mm which makes Ring-11 applicable not only for vessels, process tanks and storage tanks, but also particularly for pipelines or other applications with constricted space. Based on the fork resonant principle, when a fork vibrates in harmonic resonance comes in contact with a measured liquid, its vibration frequency will greatly decrease. The fork's harmonic resonant frequency has been precisely pre-adjusted to achieve high sensitivity, which enables the sensor to detect fluids with density as low as  $0.5\text{g/cm}^3$ . Hastelloy C-22 is available for a better corrosion-resistant performance. Jiwei Ring-11 Liquid Level Switch is an optimum solution for virtually all applications in acids (such as HCL, H<sub>2</sub>SO<sub>4</sub>, H<sub>2</sub>SO<sub>3</sub>), alkali liquids, syrup, medical liquids, and industrial wastewater, etc. Particularly, for the point level detection in pressured liquefied gas, LNG and complex applications where liquids are easy to foaming, bubbling or with high viscosity and under vibration disturbance environments. The special setting of gas-tight leadthrough makes Ring-11 effectively prevent accidental leakage from high-pressure strong corrosive liquids.

Ring-11 has qualified with SIL2 / SIL3 Certificates, as well as certified for both Intrinsic Safety and Flameproof Enclosure explosion protection. Currently, Jiwei has been granted an invention patent (ZL201510735568.2) and an utility model patent (ZL201520009337.9) on Ring-11 Liquid Level Switch.

### 1.2 Operating principle

Piezoelectric devices are utilized to achieve vibration drive and detection. Once resonant vibration fork comes into contact with application medium, vibration frequency of forks substantially decreases, and the output signal from piezoelectric detection device decreases accordingly. Then an integrated circuit is designed to analyze the signal from piezoelectric device and output a switch signal as a result.

### 1.3 Application

- (1) Liquefied natural gas and LNG with the density of  $0.56\text{g/cm}^3$  in transport pipelines.
- (2) Pipelines in pump protection system.
- (3) Herbicides, fungicides and insecticide in agricultural chemicals factory.

## 2 Configuration and characteristic

### 2.1 Configuration

As shown in Fig. 1, Ring-11 consists of the components:

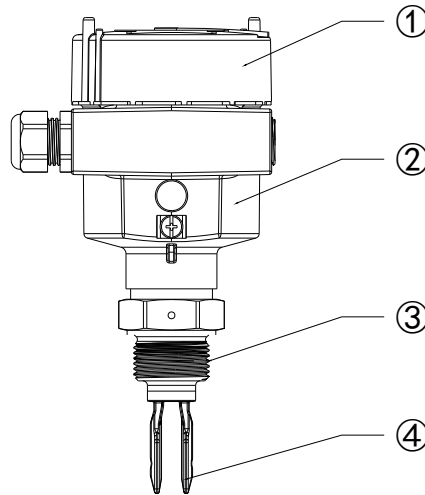

Fig. 1: Ring-11 Configuration

① Housing cover    ② Housing with electronics    ③ Process fitting    ④ Tuning fork

### 2.2 Characteristics

- (1) With only 40mm fork length, specially designed for pipelines and confined spaces.
- (2) High sensitivity due to the precisely pre-adjusted harmonic resonant frequency of the fork, the lowest detectable medium density is as low as 0.5g/cm<sup>3</sup>.
- (3) With strong anti-interference function, not influenced by foam, bubbles, viscosity, oscillation and other liquid characteristics.
- (4) Hastelloy C-22 material is optional and can withstand fluid corrosion and erosion in high temperature applications, leading the technology in China.
- (5) Industry-leading performance for high temperature applications. Process temperature can reach up to 400°C.
- (6) Four optional outputs available: relay, two-wire, NAMUR and transistor.
- (7) SIL2 / SIL3 Certificates are qualified in accordance with the IEC 61508 international standards. The certificates for Intrinsically-Safety and Explosion-Proof allow the operation in hazardous areas.

## 3 Installation

### 3.1 Before installation

Before installation, please affirm that the instrument model is suitable for the occasion and environment. In order to ensure the instrument works normally after installation, please be aware of process pressure, process temperature as well as the chemical properties of the medium.

**Installation Requirements for Ring-11 Ultra-High Temperature Model (400°C):**

(1) Water Inlet Pipe Specification: Use standard 6×4 mm (outer diameter 6 mm) copper or stainless steel tubing.

(2) Cooling Water Pressure Requirement: Recommended water pressure is 2 to 5 bar.

(3) Installation and Safety Notes:

a. The Ring-11 (400°C) model must use water cooling to operate reliably under ultra-high temperature conditions.

b. Cooling water must be connected and flowing while the probe is at ambient temperature before starting operation.

c. During operation, uninterrupted water supply must be maintained to keep the Ring-11 in a water-cooled state.

d. When stopping the cooling water supply, ensure that the Ring-11 tuning fork has returned to ambient temperature before turning off the water.

### 3.2 Installation

In general, Ring-11 can be installed in any position. The instrument can be installed horizontally, vertically, and even inclined. For viscous medium, to reduce or avoid medium hanging, please install the instrument vertically.

### 3.3 Mounting direction

Please make sure the gap between fork bodies has the same direction as medium flow. According to Fig. 2 (a) & 2 (b), to avoid measurement error caused by medium resistance or reduce buildup on the tuning fork, tuning fork should be mounted in such a way that the surfaces of the tines are parallel to the product movement.

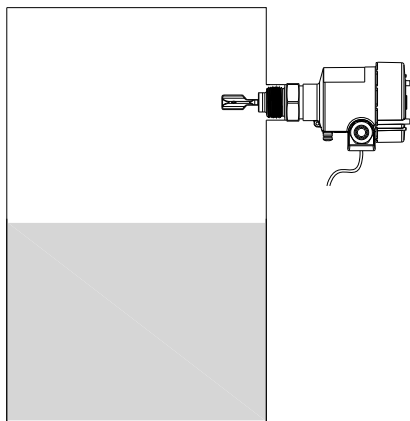

Fig. 2 (a): Vertically installation

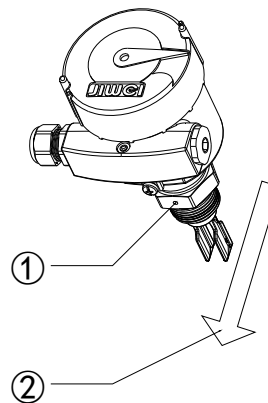

Fig. 2 (b): Flow orientation

① Marking with screwed version ② Direction of flow

### 3.4 Filling openings

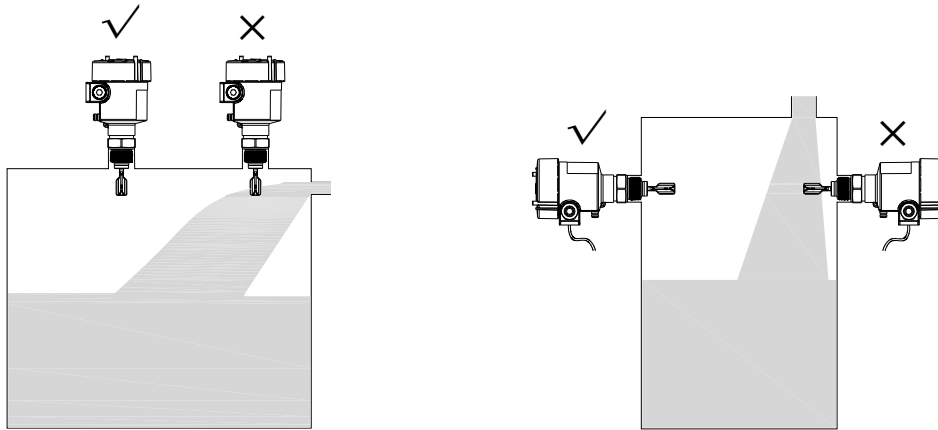

Fig. 3: Avoid mounting at filling opening

#### Notes:

- To prevent the instrument from filling impact damage or generating false signals, avoid installing instrument near inlet and outlet, as shown in Fig. 3.

### 3.5 Pressure/Vacuum

The process fitting must be sealed if there is high pressure or low pressure in the vessel or pipeline. Before mounting, please check if the seal material is suitable for the existing process conditions such as process pressure and process temperature.

### 3.6 Moisture

When the instrument is mounted in outdoors or high humidity areas, please lead the connection cable downwards in front of cable entry, thus the rain and condensation water can drain off and give your instrument additional protection against moisture penetration. See Fig. 4 as reference.

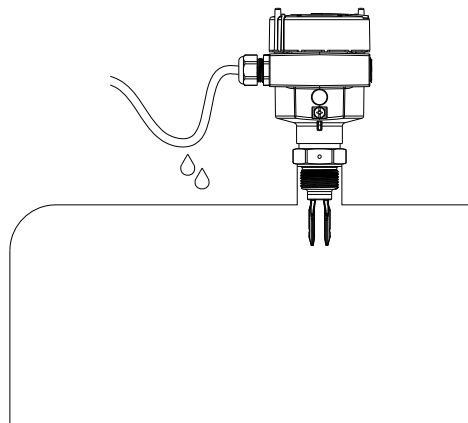

Fig.4: Moisture mounting

## 4 Electrical connection

### 4.1 Safety noted

- (1) In consideration of safety, wiring is only allowed in the complete absence of line voltage.
- (2) You must follow the corresponding installation regulations with Ex applications.

### 4.2 Connection cable

In general, Ring-11 uses general cable with round cross-section. To ensure its sealing effect, outer diameter is 5-9mm. If you are using cable with a different diameter or cross-section, please use matched cable bolt, and be aware of changed cable's sealing ability.

### 4.3 Wiring diagram

Please wiring safely according to the following diagrams (Fig. 5 - 10).

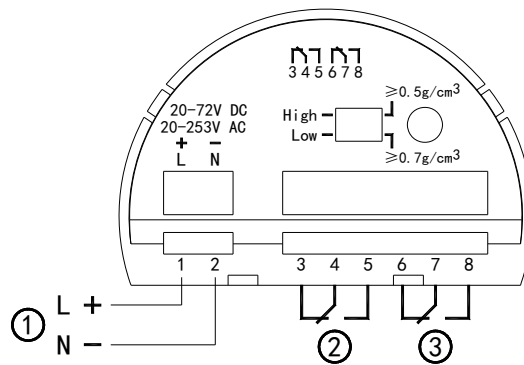

Fig.5: Relay output (DPDT)

①: Power terminal ②③: Relay output (DPDT)

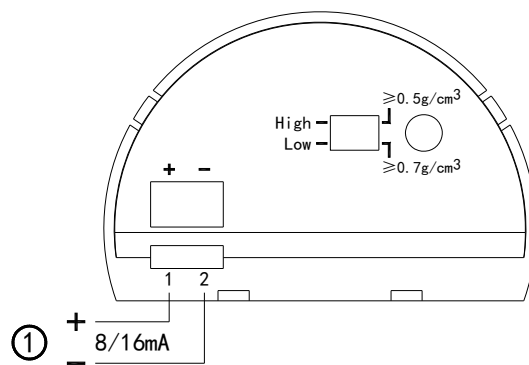

Fig.6: Two-wire output

①: Power terminal /output (8/16mA)

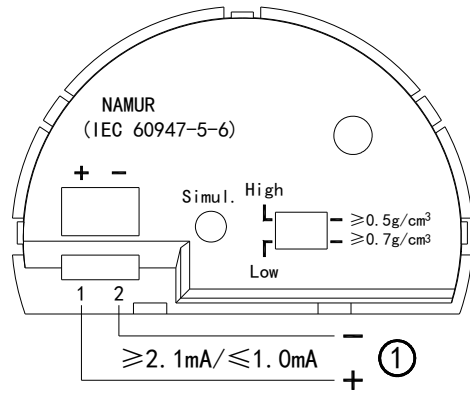

Fig. 7: NAMUR output

①: Power terminal  $\geq 2.1mA / \leq 1.0mA$  output

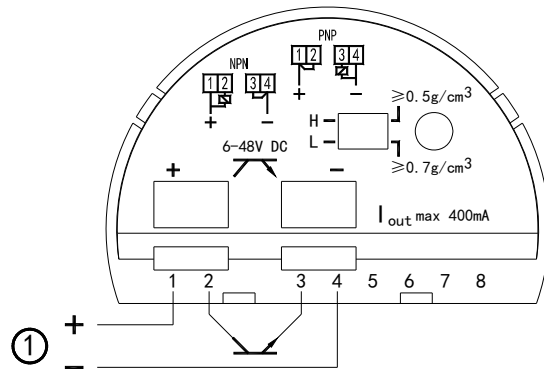

Fig. 8: Transistor (NPN/PNP) output

①: Power terminal

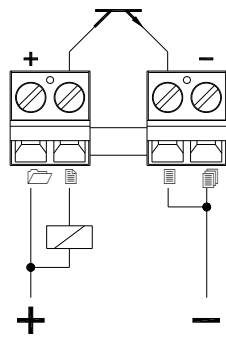

Fig. 9: NPN

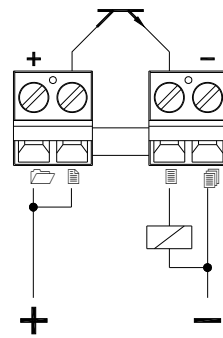

Fig.10: PNP

#### 4.4 Wiring procedure

For Ex instruments, the housing cover may only be opened if there is no explosive atmosphere present.

Proceed as follows:

- (1) Unscrew the housing cover.
- (2) Loosen the locknut on the cable gland.
- (3) Remove about 10cm (4in) of the cable mantle, strip about 1cm (0.4in) of insulation from the ends of the individual wires.
- (4) Insert the cable into the housing through the cable entry.
- (5) Unscrew the terminals with a screwdriver.
- (6) Insert the wire ends into the open terminals according to the wiring diagram.
- (7) Tighten the terminals with a screwdriver.
- (8) Check the hold of wires in the terminals by lightly pulling on them.
- (9) Tighten the locknut on the cable gland and fasten the seal ring.
- (10) Screw the housing cover.

#### 4.5 Intrinsic-safe model Ring-11 connection with safety barrier

(1) For the two-wire and NAMUR Intrinsic-safe parameters of the Ring-11 liquid level switch, refer to the explosion-proof certificate.

(2) Schematic diagram of Intrinsic-safe model Ring-11 connected with safety barrier.

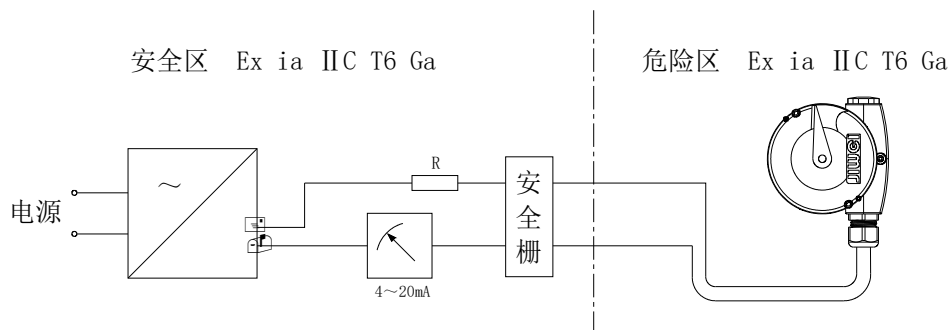

Fig.11: Intrinsic-safe model Ring-11 Connection with Safety Barrier

(3) Usage Warning:

- The housing is made of aluminum alloy. When used in Zone 0, precautions must be taken to prevent ignition risks caused by impact or friction.
- The housing contains non-metallic materials, posing a potential risk of static electricity accumulation. Avoid friction during use. Use a damp cloth for cleaning.

## 5 Setup

### 5.1 Internal structure

See Fig. 12 - 15 as reference.

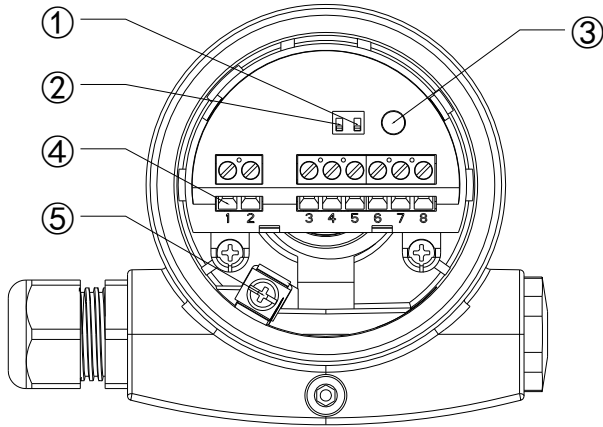

Fig.12: Relay output

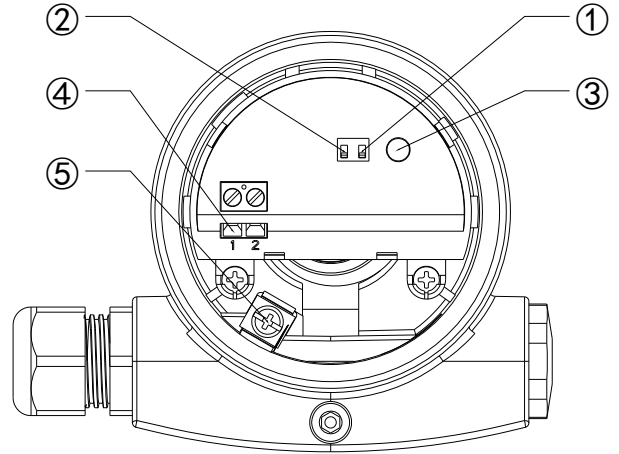

Fig.13: Two-wire output

- ① Sensitivity adjustment    ② Mode switching    ③ Signal lamp    ④ Connection terminals    ⑤ Ground terminal

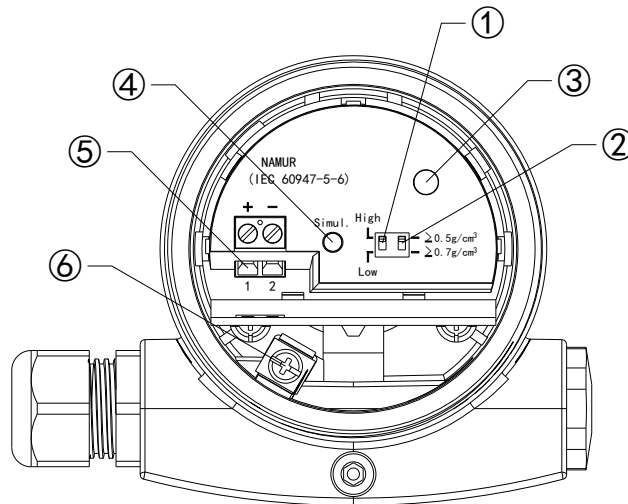

Fig. 14: NAMUR output

- ① Sensitivity adjustment    ② Mode switching    ③ Signal lamp    ④ Connection terminals    ⑤ Ground terminal  
⑥ Ground terminal

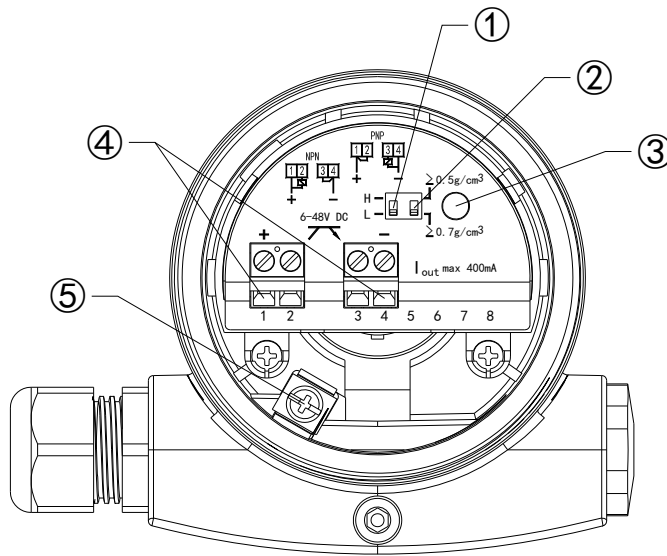

Fig. 15: Transistor (NPN/PNP) output

- ① High/low level alarm switch ② Sensitivity adjustment ③ Signal lamp ④ Ground terminal ⑤ Ground terminal

## 5.2 Sensitivity adjustment

Through adjusting the sensitivity switch on the control panel of Ring-11 makes it better to adapt to the measured liquid. As default setting, the switch is set to the low gear, liquid with density of  $\geq 0.7 \text{ g/cm}^3$  can be detected. For low density liquid, please turn the switch to a high gear (the lowest measurable density is  $0.5 \text{ g/cm}^3$ ), thus, the detection is more sensitive and more reliable.

## 5.3 Modes switch

For overflow protection and dry run protection, it should be combined with the practical requirements of the site to adjust mode switch. You can set the required mode according to the “Signal function table” in section 5.6.

## 5.4 Signal lamp

- ① Relay output:

Signal lamp for indication of the switching status:

- Green = normal
- Red = alarm
- Red (flashing) = fault

- ② Two-wire output:

Signal lamp for indication of the switching status:

- Green = normal
- Red = alarm

- Red (flashing) = fault

③ NAMUR output:

Signal lamp for indication of the switching status:

- Red = high electric current  $\geq 2.1\text{mA}$
- Switched off = low electric current  $t \leq 1.0\text{mA}$
- Red (flashing) = fault  $\leq 1.0\text{mA}$

④ Transistor(NPN/PNP) output:

- Green = normal, the output terminal has voltage output
- Red = alarm, the output terminal has no voltage output
- Red (flashing) = fault, the output terminal has no voltage output

### 5.5 Simulation button (Simul.)

Please use a suitable tool (screwdriver, ballpoint pen, etc.) to press the simulation button.

When the simulation button is pressed, the circuit interruption between the instrument and the process control unit will be simulated. The Signal lamp on the instrument will be off.

### 5.6 Signal function table

Table 1, 2 and 3 list the relay, the two-wire output and NAMUR signal corresponding to the level status.

**Table 1 Relay (DPDT) electronics module**

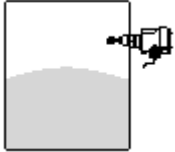
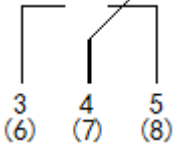
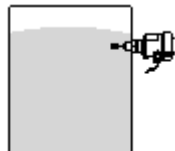
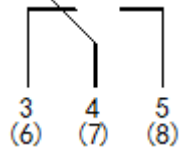
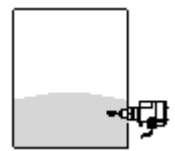
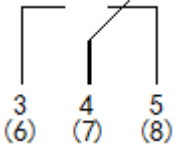
Mode	Installation location	Switching status	Signal lamp
(High) Overfill protection		 Relay energized	Green
(High) Overfill protection		 Relay de-energized	Red
(Low) Dry run protection		 Relay energized	Green

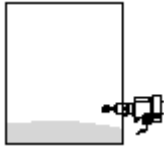
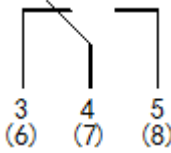
(Low) Dry run protection		 Relay de-energized	Red
Fault	Any location	Relay de-energized	Flashes red

**Table 2 Two-wire electronics module**

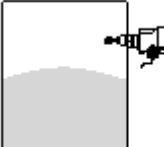
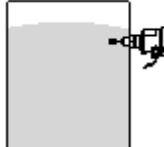
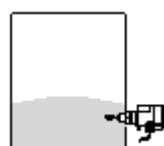
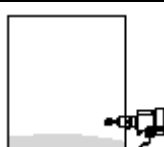
Mode	Installation location	Output Current	Signal lamp
(High) Overfill protection		8mA	Green
(High) Overfill protection		16mA	Red
(Low) Dry run protection		8mA	Green
(Low) Dry run protection		16mA	Red
Fault	Any location	~1.8mA	Flashes red

**Table 3 NAMUR electronics module**

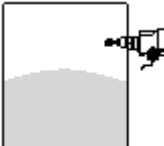
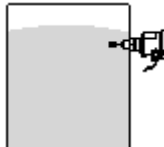
Mode	Installation location	Output Current	Signal lamp
(High) Overfill protection		$\geq 2.1\text{mA}$	Red
(High) Overfill protection		$\leq 1.0\text{mA}$	Switched off

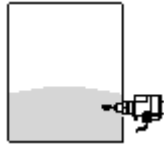
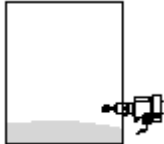
(Low) Dry run protection		$\geq 2.1\text{mA}$	Red
(Low) Dry run protection		$\leq 1.0\text{mA}$	Switched off
Fault	Any location	$\leq 1.0\text{mA}$	Flashes red

**Table 4 Transistor (NPN/PNP) electronics module**

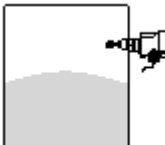
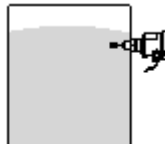
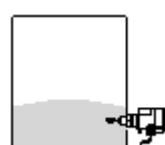
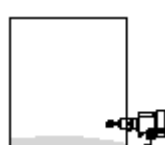
Mode	Installation location	NPN	PNP	Signal lamp
(High) Overfill protection		Conduction	Conduction	Green
(High) Overfill protection		Disconnect	Disconnect	Red
(Low) Dry run protection		Conduction	Conduction	Green
(Low) Dry run protection		Disconnect	Disconnect	Red
Fault	Any location	Disconnect	Disconnect	Flashes red
Power supply interruption	Any location	Disconnect	Disconnect	Flashes red

**Safety note:**

When testing the function of Ring-11, do NOT hold the fork body by hands, it may damage the sensor, even distort the fork body.

## 6 Fault analysis and maintenance

### 6.1 Fault analysis

The operator of the instrument is responsible for taking suitable inspections to rectify faults.

Ring-11 offers maximum quality and reliability. Nevertheless, faults may occur during operation.

These may be caused by the following:

- Electronics module
- Voltage supply
- Installation location
- Vibrating fork body

When faults occur, the first inspection to be taken is to check the output signal. In many cases, the causes can be determined this way and the faults rectified. See Table 3 as reference.

**Table 3 Fault analysis**

Fault type	Fault analysis	Fault rectification
Ring-11 signal error reporting when dry run protection or overflow protection	Operating voltage too low	Check operating voltage
	Electronics defective	Push the mode switch inversely, if instrument then changes the mode, the tuning fork may be covered with buildup or mechanically damaged. If the switching function is in the correct mode, the instrument still is faulty, return the instrument for repair.
		Push the mode switch inversely, if instrument then does not change the mode, the electronics module may be defective, please exchange the electronics module.
	Unfavorable installation location	Mount the instrument at a location in the vessel where no dead zones or air bubbles can form.
	Buildup on the tuning fork	Check the tuning fork if there is buildup and remove it.
	Wrong mode selected	Reset the correct mode on the mode switch (overflow protection, dry run protection).
Signal lamp flashes red	Damage on the tuning fork	Check if the tuning fork is damaged or extremely corroded.
	Electronics defective	Exchanging the electronics module.
	Damage to other parts of the instrument	Exchange the instrument or send it in for repair.

Depending on the reason for the fault and the inspections taken, the steps described in chapter “Set up” may have to be carried out again.

### 6.2 Exchanging the electronics

If the electronics module is defective, in order to continue using the instrument, it is recommended to replace the electronic module. In Ex applications, you should pay attention to the electronics

module with respective Ex approval.

In general, all electronics modules of Ring-11 can be replaced with each other. However, if the electronics module with a different signal output, not the same, you should pay attention to make the appropriate adjustments and select the matching requirements of the electronics module.

### 6.3 Instrument repair

We offer our customers service including technical consulting, user training, on-site installation and commissioning, product replacement and maintenance as well as on-site technical support, etc. Jiwei product quality warranty period is one year, the warranty period for your free maintenance, long-term technical support, if you need advice in use, please call the service hotline: +86-0755-28407683, you can find the relevant services on our website “www.jiweiauto.cn”.

## 7 Technical data

Applicable liquid	Density	$\geq 0.5\text{g/cm}^3$
	Viscosity	$0.1 \sim 10000\text{mPa}\cdot\text{s}^{①}$
	Flow velocity	Max. 6m/s
Probe data	Surface finish	$Ra < 0.5\mu\text{m}^{②}$
	Vibration frequency	$\sim 1200\text{Hz}$
	Fork length	40mm
Accuracy	Measurement error	$\pm 1\text{mm}$
	Delay	2mm
	Repeatability	0.1mm
Switching delay	When immersed	0.5s
	When laid bare	1s
Power supply <sup>③</sup>	Relay	20~253V AC/20~72V DC
	Two-wire	10~36V DC
	NAMUR	8.2V DC
	Transistor	6~48V DC
	Max. power consumption	8VA(AC); 1.5W(DC)
Output	Relay	5A/253V AC/24V DC
	Two-wire	8mA/16mA, Alarm<2.3mA
	NAMUR	$\leq 1\text{mA}$ or $\geq 2.1\text{mA}$ , Fault $\leq 1\text{mA}$
	Transistor	NPN/PNP
Installation conditions <sup>④</sup>	Process pressure	-1~64bar
	Process temperature	Regular temperature: -50~150°C
		High temperature: -50~280°C
		Ultra-high temperature: -50~400°C <sup>⑤</sup>
	Ambient temperature	-50~70°C
Storage and transport temperature	-40~80°C	
Overvoltage protection	Relay	Category III, class I
	Two-wire	Category III, class II
Certificates and approvals	SIL Qualification <sup>®</sup>	SIL2 (HFT=0) / SIL3 (HFT=1)
	Explosion-Proof	Dust Flameproof Enclosure: Ex db IIC T6...T1 Gb Ex tb IIIC T440°C...T80°C Db
		Intrinsic Safety: Ex ia IIC T1...T6 Ga
	CE	LVD and EMC Certificates
Ingress Protection	IP66/IP67	

Materials	Housing	Aluminum alloy, , stainless steel
	Ground terminal	316L
	Thread connection	316L
	Flange connection	316L, 316L coated Enamel, ECTFE, PFA
	Fork	316L, 316L coated Enamel, ECTFE, PFA
	Process seal	Klingersil C-4400

**Note:** ① Assume the medium density equals to 1.

② Applicable: for Hygienic Ring-11 only.

③ The voltage of explosion-proof models can be executed according to the technical requirements on the Explosion-proof Certificate.

④ The relationship between the process temperature, medium temperature and ambient temperature of explosion-proof models can be executed according to the technical requirements on the Explosion-proof Certificate.

⑤ Cover the exhaust port with the whistle, keeping the whistle's outlet side close against the port wall. Gradually increase the cooling gas flow until the whistle emits a sound—this indicates the minimum required flow rate.

⑥ Comply with international standard IEC61508 (national standard GB/T20438).

### Ex certificate

This instrument fulfills the legal requirements of the applicable Ex guidelines. You can find the Ex conformity declaration in the certification area of “[www.jiweimeter.cn](http://www.jiweimeter.cn)”.

### Protection rating

This instrument fulfills the legal requirements of the applicable GB guidelines. The housing version with protection rating IP66/67. You can find the GB conformity declaration in the certification area of “[www.jiweiauto.com](http://www.jiweiauto.com)”.

## 8 Dimensions

### Ring-11 Flange Version

Standard  
(regular temperature)

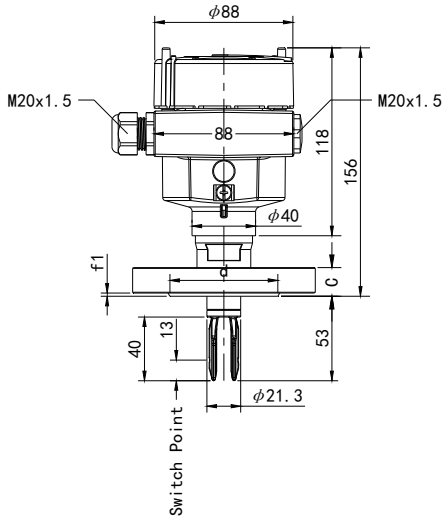

Extended  
(regular temperature)

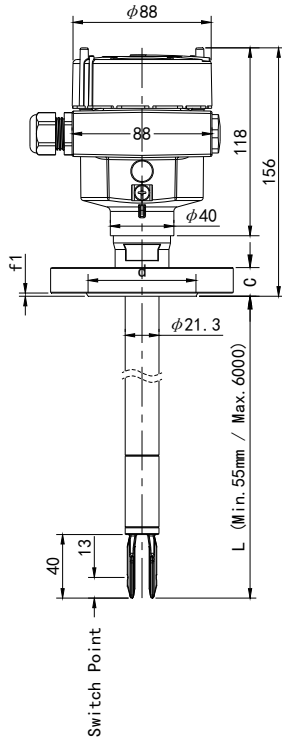

Standard  
(high temperature)

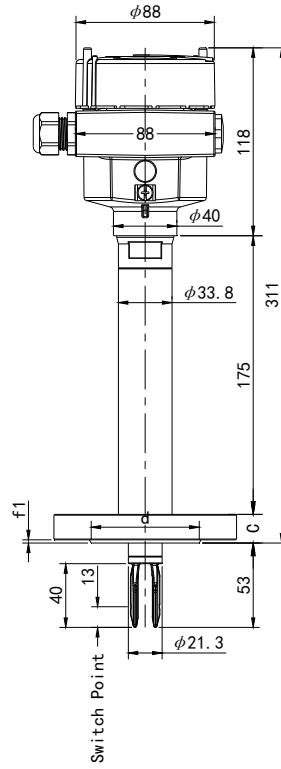

Extended  
(high temperature)

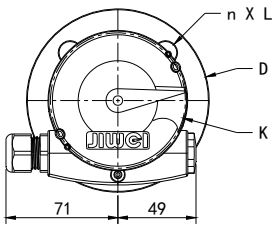
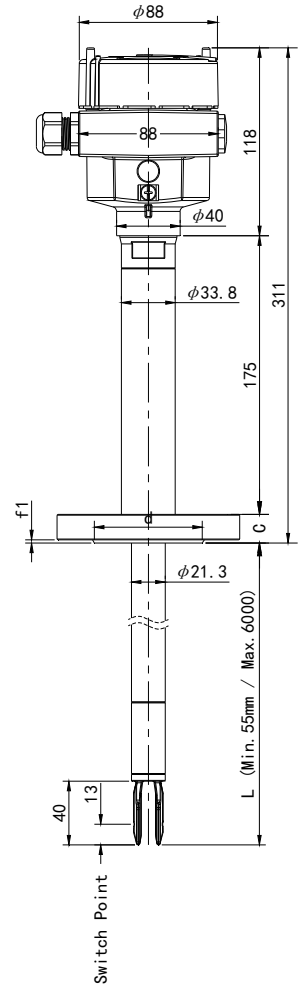

## Ring-11 Threaded Version

Standard  
(regular temperature)

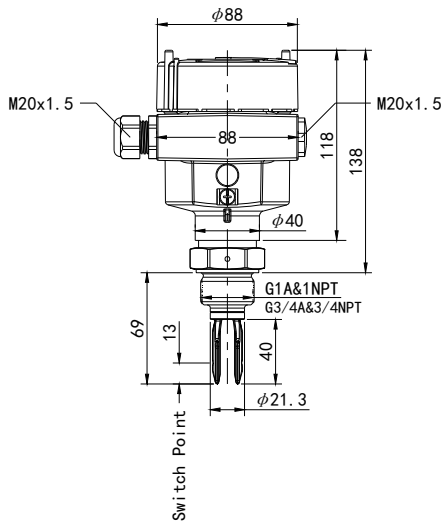

Extended  
(regular temperature)

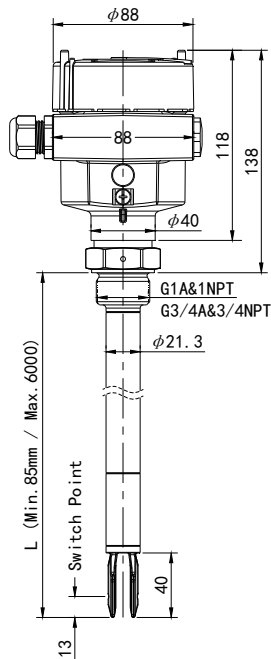

Standard  
(high temperature)

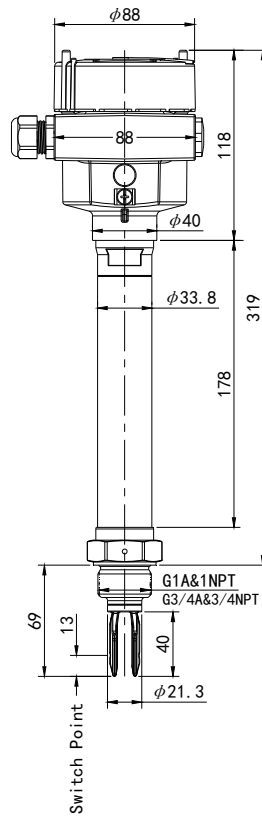

Extended  
(high temperature)

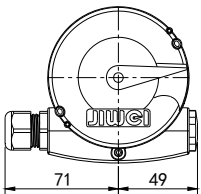
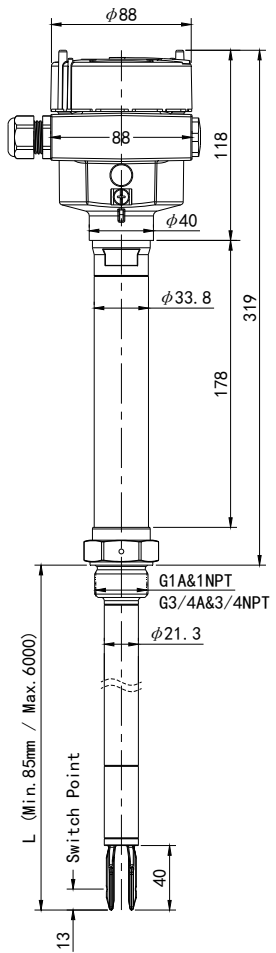

Ring-11 Ultra-high temp

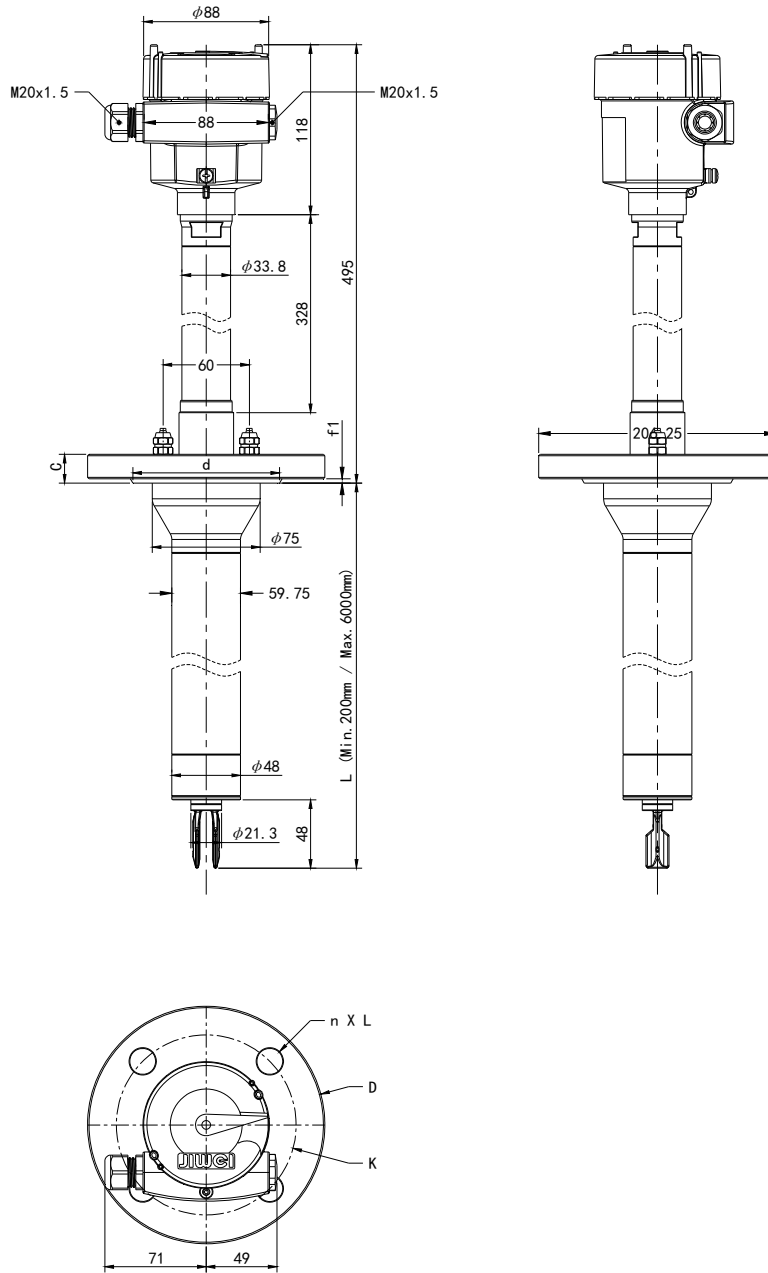

## 9 Storage and transport

### 9.1 Packaging

Your instrument was protected by packaging during transport.

The packaging of standard instruments consists of environment friendly, recyclable carton cover material .The probe is additionally protected with a cardboard cover. For special version, PE foam or PE foil is also used. Please dispose of the packaging material through specialized recycling companies.

### 9.2 Transport

Transport must be carried out under consideration of the notes on the transport packaging. Nonobservance of these instructions can cause damage to the instrument.

The delivery must be checked for completeness and possible transit damage immediately at receipt .Ascertained transit damage or concealed defects must be appropriately dealt with.

### 9.3 Storage

The packages must be stored under the following conditions:

- (1) Not in the open
- (2) Dry and dust free
- (3) Not exposed to corrosive media
- (4) Protected against solar radiation
- (5) Avoiding mechanical shock and vibration
- (6) Storage environment
  - Relative humidity: 20~85%
  - Storage temperature: -40~80℃