

# Contents

<b>1 INTRODUCTION .....</b>	<b>- 1 -</b>
1.1 BRIEF DESCRIPTION .....	- 1 -
1.2 OPERATING PRINCIPLE .....	- 1 -
1.3 APPLICATION .....	- 1 -
<b>2 CONFIGURATION AND CHARACTERISTIC .....</b>	<b>- 1 -</b>
2.1 CONFIGURATION .....	- 1 -
2.2 CHARACTERISTIC .....	- 2 -
<b>3 INSTALLATION .....</b>	<b>- 2 -</b>
3.1 BEFORE INSTALLATION .....	- 2 -
3.2 INSTALLATION .....	- 2 -
3.3 MOUNTING DIRECTION .....	- 2 -
3.4 FILLING OPENINGS .....	- 2 -
3.5 PRESSURE/VACUUM .....	- 3 -
3.6 MOISTURE .....	- 3 -
<b>4 ELECTRICAL CONNECTION .....</b>	<b>- 4 -</b>
4.1 SAFETY NOTED .....	- 4 -
4.2 CONNECTION CABLE .....	- 4 -
4.3 WIRING DIAGRAM .....	- 4 -
<b>5 SET UP .....</b>	<b>- 5 -</b>
5.1 MODES SWITCH .....	- 5 -
5.2 SIGNAL LAMP .....	- 6 -
<b>6 FAULT ANALYSIS AND MAINTENANCE .....</b>	<b>- 9 -</b>
6.1 FAULT ANALYSIS .....	- 9 -
6.2 INSTRUMENT REPAIR .....	- 9 -
<b>7 TECHNICAL DATA .....</b>	<b>- 9 -</b>
<b>8 DIMENSIONS .....</b>	<b>- 11 -</b>
<b>9 STORAGE AND TRANSPORT .....</b>	<b>- 13 -</b>
9.1 PACKAGING .....	- 13 -
9.2 TRANSPORT .....	- 13 -
9.3 STORAGE .....	- 13 -

## 1 Introduction

### 1.1 Brief description

Ring-21 is an economical compact tuning fork liquid level switch with maximum reliability and safety. It is also based on the principle that vibrating frequency changes when the fork detects the presence of a liquid. Designed with a lightweight compact structure with the fork body 38mm long, total length is 160.5mm and maximum diameter 31.5mm, Ring-21 is an ideal choice for small vessels within confined spaces. The detectable density is as low as 0.7g/cm<sup>3</sup>.

### 1.2 Operating principle

Same as Ring-11, Ring-21 Compact Liquid Level Switch is based on fork resonant principle. When fork tines which vibrates in harmonic resonance immerses into fluids, vibrating frequency of the fork will greatly decrease, so does the output of piezoelectric detection device. An integrated circuit is designed to analyze signal from piezoelectric device and output a switching signal.

### 1.3 Application

- (1) Confined space applications that expecting low cost, in non-explosive environments.
- (2) Pipelines in pump protection system.
- (3) Level measurement and control with process temperature within 150 °C.

## 2 Configuration and characteristic

### 2.1 Configuration

As shown in Fig.1, Ring-21 consists of the components:

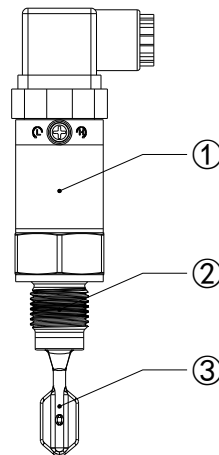

Fig. 1: Ring-21 Configuration

- ① Housing with electronics    ② Process fitting    ③ Tuning fork

## 2.2 Characteristic

- (1) Compact and portable, with overall length 160.5mm, maximum diameter 31.5mm and the fork body only 38mm long.
- (2) Particularly suitable for pipelines and other applications within confined space.
- (3) With CE certificates. Economical, simple, high-performance, low-cost, and long-lasting
- (4) Highly reliable because of detecting changed of vibrating frequency of the fork.
- (5) Simple setup, maintenance free.

## 3 Installation

### 3.1 Before installation

Before installation, please affirm that the instrument model is suitable for the occasion and environment. In order to ensure the instrument works normally after installation, please be aware of process pressure, process temperature as well as the chemical properties of the medium.

### 3.2 Installation

In general, Ring-21 can be installed in any position. It can be installed horizontally, vertically, and even inclined. If the measured medium is viscous, to reduce or avoid medium hanging, please install the instrument vertically.

### 3.3 Mounting direction

Please make sure the gap between fork bodies has the same direction as medium flow. According to Fig. 2, to avoid measurement error caused by medium resistance, tuning fork should be mounted in such a way that the surfaces of the blades are parallel to the product movement.

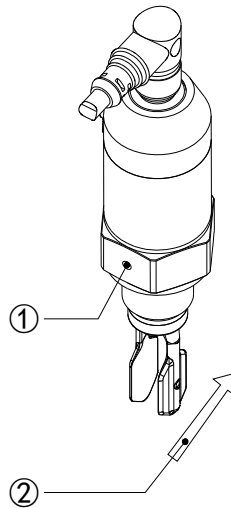

Fig. 2: Flow orientation of the tuning fork

- ① Marking with screwed version    ② Direction of flow

### 3.4 Filling openings

As shown in Fig.3, when choosing mounting position, avoid mounting Ring-21 at filling openings, in order to prevent measurement error, even instrument damage caused by material impact, it should be mounted in such a way that the tuning fork does not protrude directly into the filling

stream.

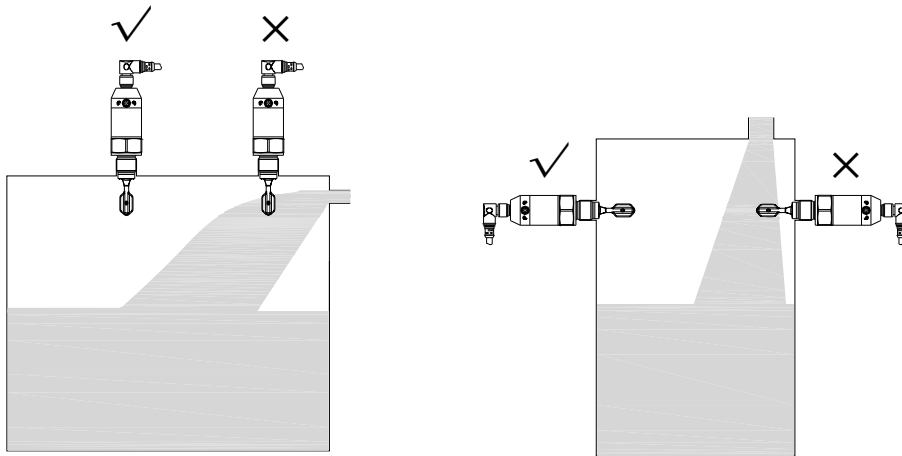

Fig.3: Avoid mounting at filling opening

### 3.5 Pressure/Vacuum

The process fitting must be sealed if there is high pressure or low pressure in the vessel or pipeline. Before mounting, please check if the seal material is suitable for the existing process conditions such as process pressure and process temperature.

### 3.6 Moisture

When the instrument is mounted in outdoors or high humidity areas, please lead the connection cable downwards in front of cable entry, thus the rain and condensation water can drain off and give your instrument additional protection against moisture penetration. See Fig. 4 as reference.

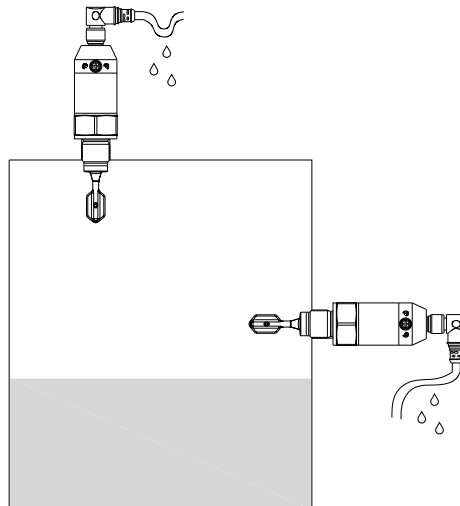

Fig. 4: Against moisture penetration

## 4 Electrical connection

### 4.1 Safety noted

(1) In consideration of safety, wiring is only allowed in the complete absence of line voltage.

### 4.2 Connection cable

In general, Ring-21 uses general cable with round cross-section. To ensure its sealing effect, the outer diameter is 4.5-8mm.

If you are using cable with a different diameter or cross-section, please use a matched cable bolt, and be aware of the sealing performance.

### 4.3 Wiring diagram

Please wiring safely according to the following diagrams.

Fig. 5, 6, 7 and 8 are the wiring plans for M12×1 connection:

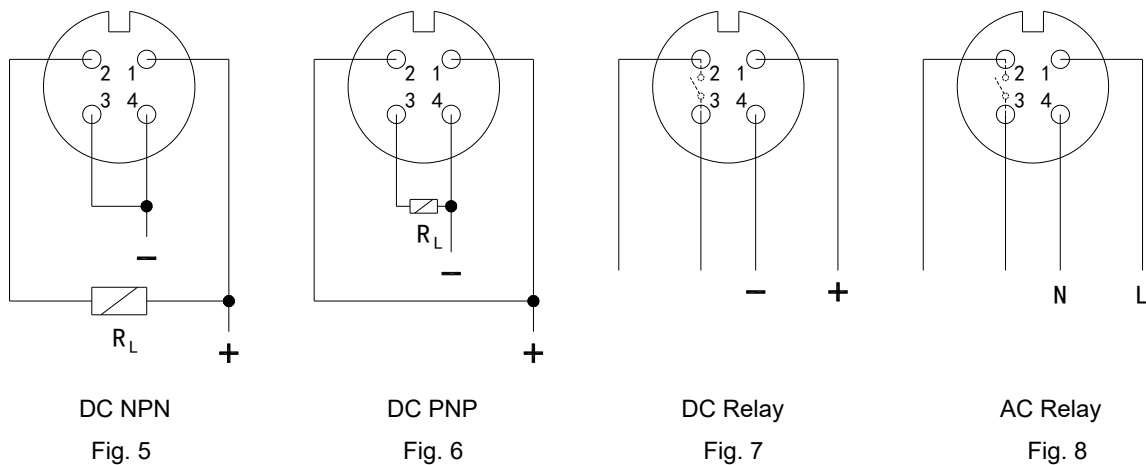
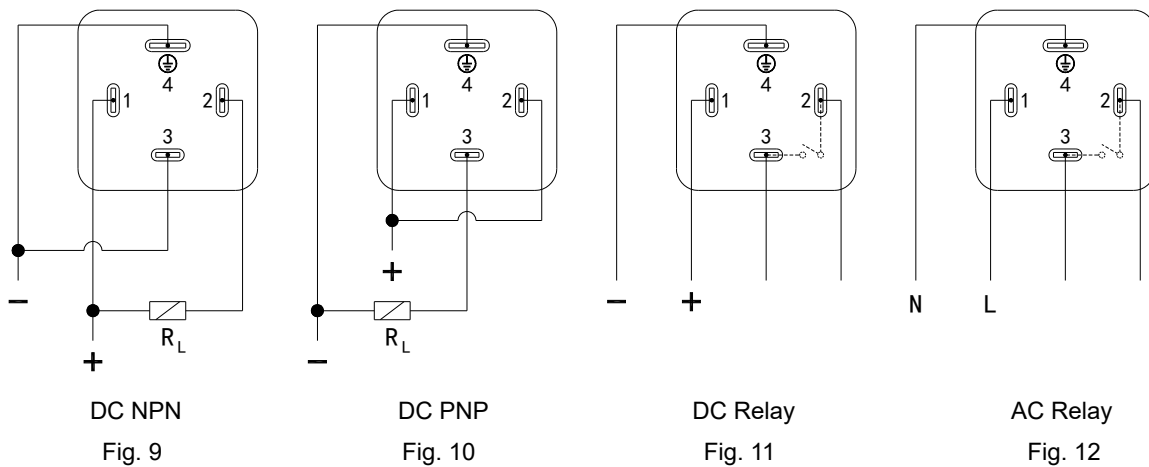

Fig. 9, 10, 11 and 12 are the wiring plans for the connector of solenoid valve:



**Note:** 1. RL is load resistance (contactor, relay etc.)

2. The cables of M12×1 are not equipped with Ring-21. Clients can choose the right cable fitting or make a requirement for us. Our M12×1 cable fittings are marked as: brown-1, white-1, blue-3 black-4. Be aware of distinguishing when wiring.

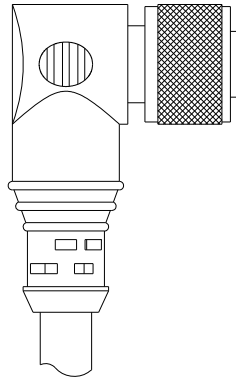

Fig. 13 Cable fittings of M12×1 wiring plan

## 5 Set up

### 5.1 Modes switch

For overflow protection and dry run protection, it should be combined with the practical requirements of the occasion to adjust mode switch (High/Low level).

Proceed as follows:

- (1) Use a screwdriver to unscrew partial screws on the housing (See Fig. 14), the electronic potentiometer is inside.
- (2) Use a straight screwdriver to slightly rotate the electronic potentiometer clockwise to the end, so the instrument is in “High level” mode. (See Fig. 15)
- (3) Use a straight screwdriver to slightly rotate the electronic potentiometer counterclockwise to the end, so the instrument is in “Low level” mode. (See Fig. 15)
- (4) After setting the mode, please screw the screws tightly, and reconnect the power. (See Fig. 16)

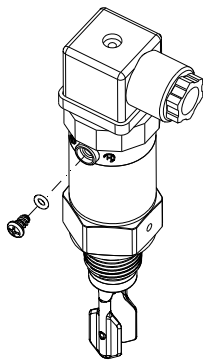

Fig. 14

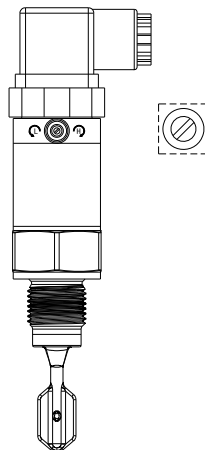

Fig. 15

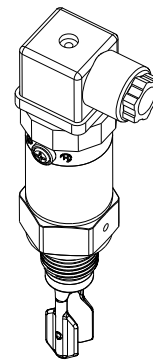

Fig. 16

## 5.2 Signal lamp

Signal lamp for indication of the switching status:

- Green = normal
- Red = alarm
- Red (flashing) = fault

Table 1 lists the signal lamp of relay, corresponding to high and low level modes after the instrument is connected.

## 5.3 Signal output table

Relay switch for single pole single throw (SPST).

Table 1 lists the signal output status in the high and low level modes corresponding to the relay output in the normally closed (NC) mode:

**Table 1 Relay output in the normally closed (NC) mode**

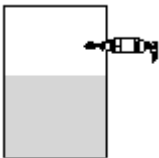
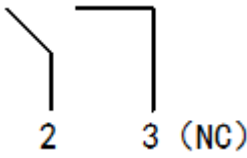
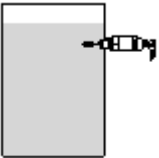
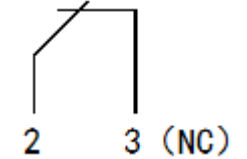
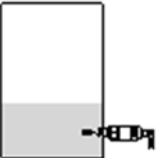
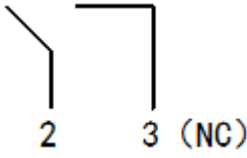
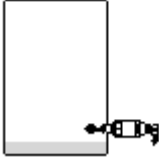
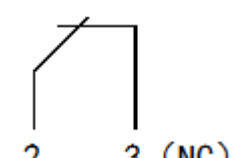
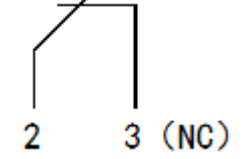
Level modes	Installation location	Relay output	Signal lamp
(High) Overfill protection			Green
(High) Overfill protection			Red
(Low) Dry run protection			Green
(Low) Dry run protection			Red
Fault	Any location		Flashes red

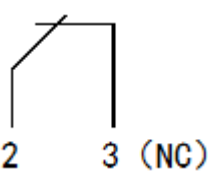
Level modes	Installation location	Relay output	Signal lamp
Powered-off	Any location		Lights-off

**Note:** Above figures are the default settings after powered-on of relay output for the normally closed (NC) mode, 2 is the common point, 3 is normally-closed contact. The contact of both normally-closed and normally-opened can be customized.

Table 2 lists the signal output status in the high and low level modes corresponding to the relay output in the normally opened (NO) mode:

**Table 2 Relay output in the normally opened (NO) mode**

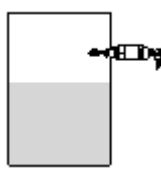
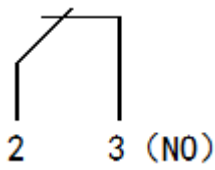
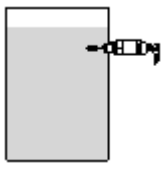
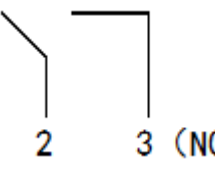
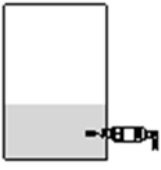
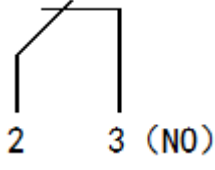
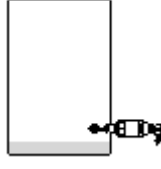
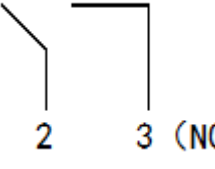
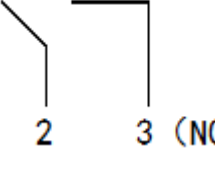

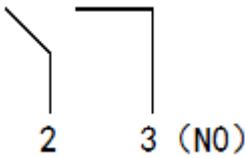
Level modes	Installation location	Relay output	Signal lamp
(High) Overfill protection			Green
(High) Overfill protection			Red
(Low) Dry run protection			Green
(Low) Dry run protection			Red
Fault	Any location		Flashes red

Level modes	Installation location	Relay output	Signal lamp
Fault/ Powered-off	Any location		Lights-off

**Note:** Above figures are the default settings after powered-on of relay output for the normally opened (NO) mode, 2 is the common point, 3 is normally-opened contact. The contact of both normally-closed and normally-opened can be customized.

Table 3 lists the signal output status in the high and low level modes corresponding to NPN / PNP output mode:

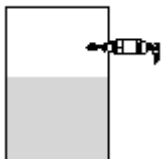
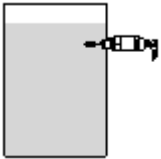
**Table 3 NPN/PNP output**

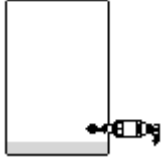
Level modes	Installation location	NPN	PNP	Signal lamp
(High) Overfill protection		Connect	Connect	Green
(High) Overfill protection		Disconnect	Disconnect	Red
(Low) Dry run protection		Connect	Connect	Green
(Low) Dry run protection		Disconnect	Disconnect	Red
Fault	Any location	Disconnect	Disconnect	Flashes red
Powered-off	Any location	Disconnect	Disconnect	Lights-off

**Note:** When testing, do NOT hold the tines by hands, it may distort or even damage.

## 6 Fault analysis and maintenance

### 6.1 Fault analysis

The operator of the instrument is responsible for taking suitable inspections to rectify faults.

Ring-21 offers high quality and reliability. Nevertheless, faults may occur during operation. These may be caused by the following:

- Electronics module
- Voltage supply
- Installation location
- Vibrating fork body

When faults occur, the first inspection to be taken is to check the output signal. In many cases, the causes can be determined this way and the faults rectified. See Table 3 as reference.

**Table 4 Fault analysis**

Fault type	Fault analysis	Fault rectification
Green lamp off	Operating voltage too low	Check operating voltage
	Electronics defective	Exchanging the electronics module
	No voltage supply	Check voltage supply and cable wiring condition.
Red lamp Flashes	Damage on the tuning fork	Check if the tuning fork is damaged or extremely corroded.
	Damage to other parts of the instrument	Exchange the instrument or send it back for repair.

Depending on the reason for the fault and the inspections taken, the steps described in chapter “Set up” may have to be carried out again.

### 6.2 Instrument repair

We offer our customers service including technical consulting, user training, on-site installation and commissioning, product replacement and maintenance as well as on-site technical support, etc. Jiwei product quality warranty period is one year, the warranty period for your free maintenance, long-term technical support, if you need advice in use, please call the service hotline: +86 755 28407683, you can find the relevant services on our website “www.jiweimeter.cn.

## 7 Technical data

### Housing

PlasticPC

### Process fitting

Thread 316L

### Probe

Tuning fork 316L

### Surface quality

Standard version 3µm

Hygienic version	<0.8μm; <0.3μm
<b>Instrument weight</b>	250g
<b>Measuring frequency</b>	approximate 1100 Hz
<b>Ambient conditions</b>	
Ambient temperature on the housing	-40~70°C
Storage and transport temperature	-40~80°C
<b>Process conditions</b>	
Process pressure	-1~40bar
Process temperature(Normal temperature)	-50~100°C
Process temperature(High temperature)	-50~150°C
<b>Sensitivity switch (The lowest density)</b>	
Density	>0.7g/cm <sup>3</sup>
<b>Modes switch</b>	
High	overflow protection
Low	dry run protection
<b>Switching delay</b>	
When immersed	0.5S
When laid bare	1S
<b>Measuring accuracy</b>	
Measured deviation	±1mm
Switching delay	3.0±0.5mm
Repeatability	0.1mm
<b>Electronics</b>	
Relay	SPST
Relay rated load	AC 125V 0.5A; DC 24V 1A
NPN/PNP	Load current <300mA; Voltage drop <1.6V
<b>Operating voltage</b>	
Relay	85~253VAC/10~35VDC
NPN/PNP	10~35V DC
<b>CE Certificates</b>	LVD and EMC certificates
<b>Electrical protective measures</b>	
Protection rating	
M12×1	IP66/67
Connector of solenoid valve	IP65

### Approvals

Instruments with approvals can have different technical data depending on the version. For that reason the associated approval documents of these instruments have to be carefully noted. You can find the approvals in the certification area of “[www.jiweimeter.cn](http://www.jiweimeter.cn)”.

### Protection rating

This instrument fulfills the legal requirements of the applicable GB guidelines, with protection IP65 and IP66/67. You can find the GB conformity declaration in the download area of “[www.jiweimeter.cn](http://www.jiweimeter.cn)”.

8 Dimensions

Ring-21 Regular Temperature

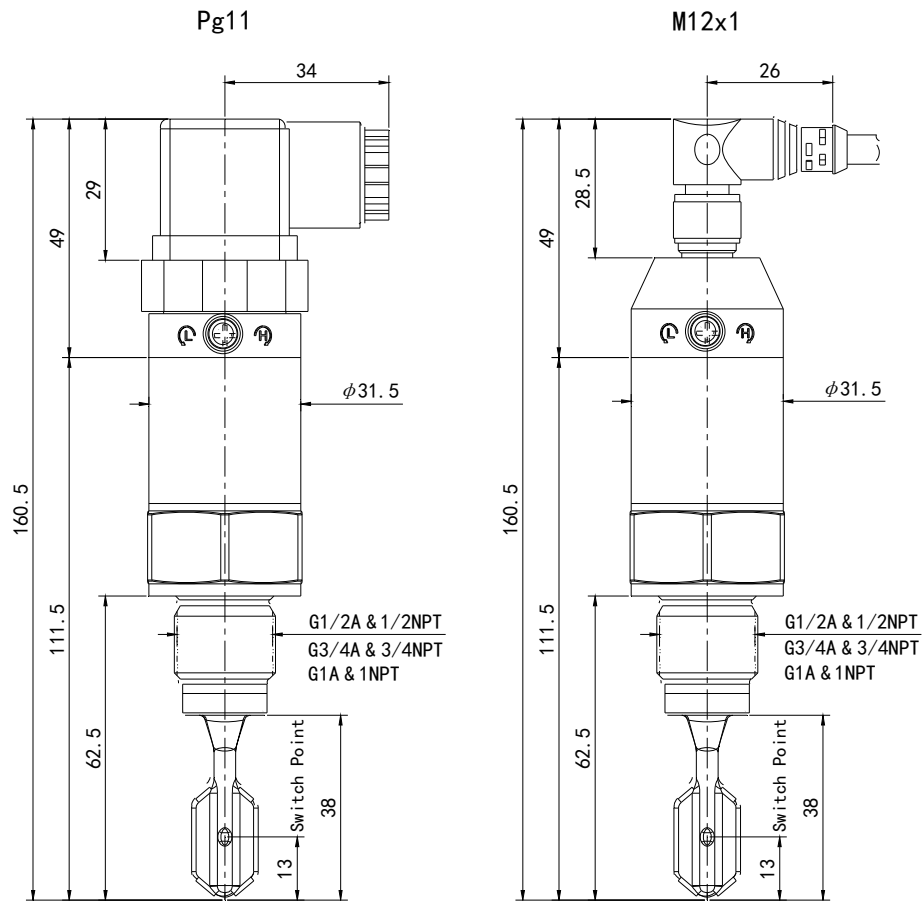

Ring-21 High Temperature

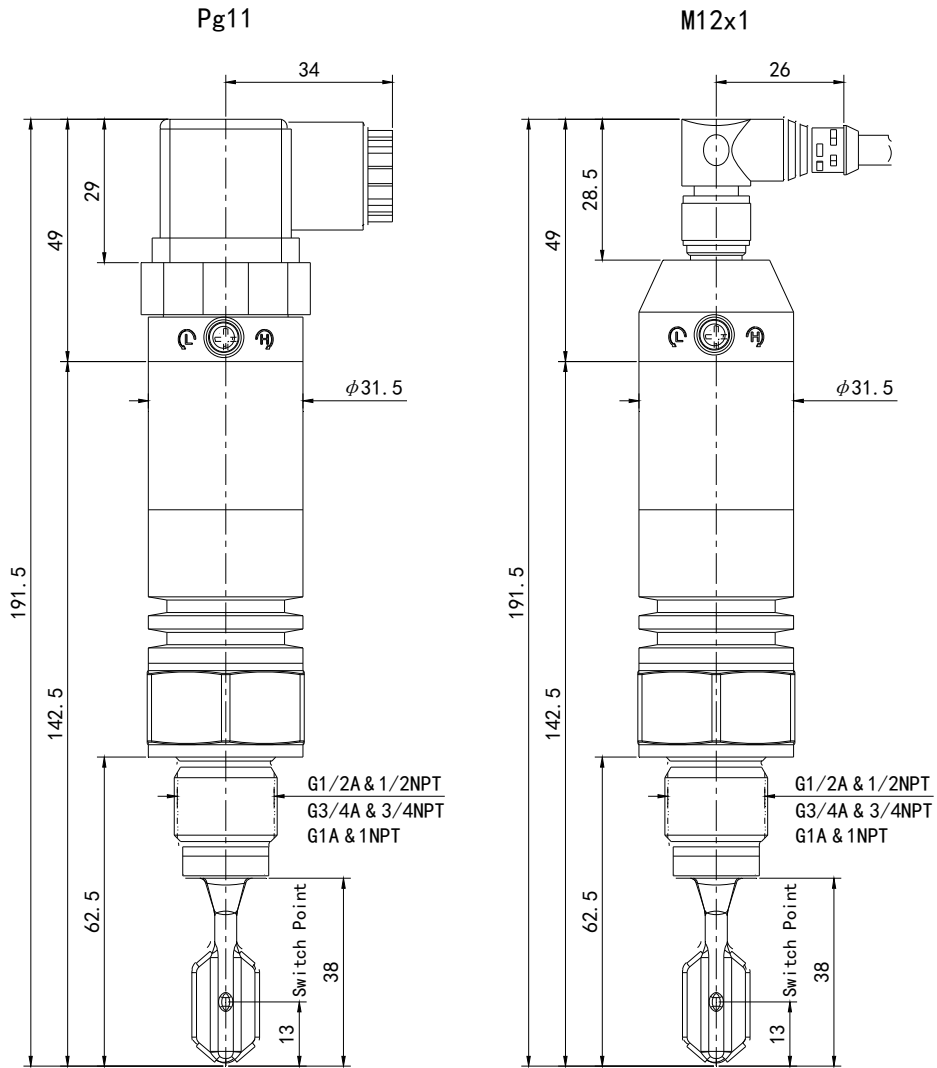

## 9 Storage and transport

### 9.1 Packaging

Your instrument was protected by packaging during transport.

The packaging of standard instruments consists of environment friendly, recyclable carton cover material. The probe is additionally protected with a cardboard cover. For special versions, PE foam or PE foil is also used. Please dispose of the packaging material through specialized recycling companies.

### 9.2 Transport

Transport must be carried out under consideration of the notes on the transport packaging. Nonobservance of these instructions can cause damage to the instrument.

The delivery must be checked for completeness and possible transit damage immediately at receipt. Ascertained transit damage or concealed defects must be appropriately dealt with.

### 9.3 Storage

The packages must be stored under the following conditions:

- (1) Not in the open
- (2) Dry and dust free
- (3) Not exposed to corrosive media
- (4) Protected against solar radiation
- (5) Avoiding mechanical shock and vibration
- (6) Storage environment

Relative humidity: 20~85%;

Storage temperature: -40~80°C